

A 3D rendered scene featuring a blue grid floor that recedes into the distance. Several geometric shapes are floating in the air: a yellow cube in the upper left, a red sphere in the upper right, a yellow ring in the middle left, a blue ring in the middle right, and a red sphere in the lower right. The main title is centered in the scene.

INDUSTRIAL DESIGN PORTFOLIO

SKAND

2020

SKAND SHEKATKAR

- INDUSTRIAL DESIGN -



EDUCATION

Srishti Institute of Art, Design and Technology
Industrial Design (2017- Ongoing)
Bangalore, India

Fergusson College
(11th & 12th) Arts and Humanities (2015-2017)
Pune, India.

ACHIEVEMENTS

OLYMPAC Participant 2019 (18 countries)
Represented India in a Live Packaging Design
Contest held by Japan Foundation and Japan
Packaging Design Association
TOKYO, JAPAN

ASPAC : Honorable Award 2019
(Asian Students Packaging Design Competition)
TOKYO, JAPAN

3RD POSITION in "Healthy Crossroads in
Pregnancy Care Design Challenge 2018"
(Team of two members)

WORK EXPERIENCE

Josmo Studio (May-July 2019)

Key Responsibilities:

Assisting the Design team on live
projects. Coming up with concepts
for new products. 3D modelling,
Technical drawings and concept
sketches. Assisting Production Team
occasionally

SOFTWARES

SOLIDWORKS
KEYSHOT
RHINO
AUTOCAD
LUMION
ILLUSTRATOR
PHOTOSHOP
LIGHTROOM
INDESIGN
PREMIERE PRO

An enthusiastic soul always looking for new experiences, conversations and growth. I respect Nature and always look towards it for inspiration, a firm believer of Bio-mimicry. I love exploring new production techniques and love difficult challenges. Furniture is something that I have enjoyed working with in the past and am currently looking to broaden my skillset by indulging in new products and their practices.

CONTACT

☎ +91 7588235964

✉ skandshekatkar@gmail.com

CONTENTS

01

FURNITURE
LOUNGER

pg. 4



02

PRODUCT
HAND MIXER

pg. 9



03

FURNITURE
SIDE TABLE

pg. 14

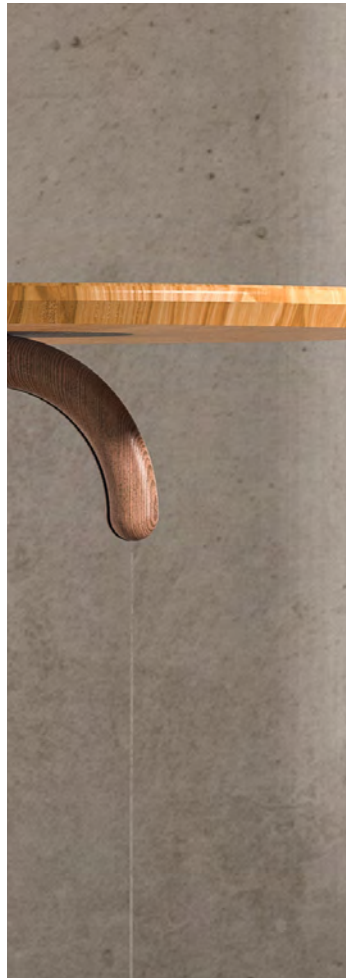

04

PACKAGING
CREAM

pg. 17



05

PRODUCT
GUITAR

pg. 20

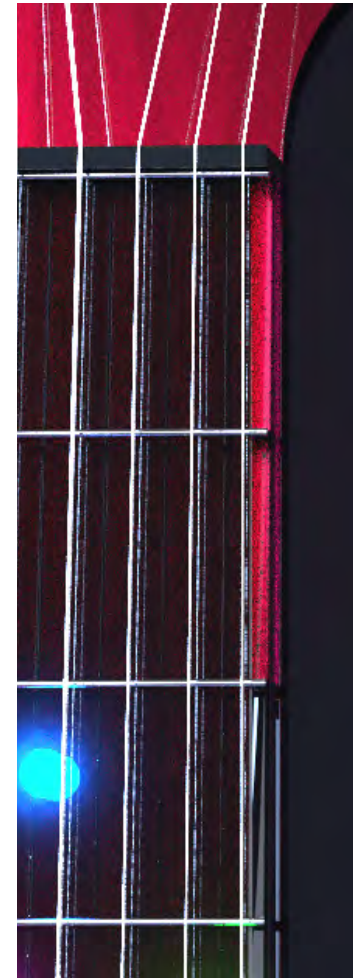

06

FURNITURE
DINNER TABLE

pg. 24



01 LOUNGER

PRODUCTION DESIGN
A study of Furniture
Production Techniques

2 WEEKS



SCAN FOR A
COOL VIDEO

The chair was designed with a focus on learning different fabrication techniques. It was made sure to include difficult woodworking and complex angles in the steel frame.



TECHNICAL DRAWINGS FOR PRODUCTION

Detailed part drawings to aid fabrication were also made, which are not included here

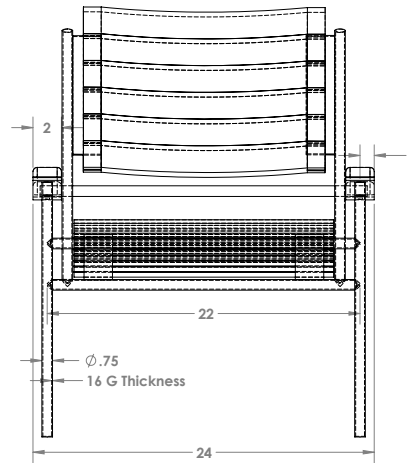
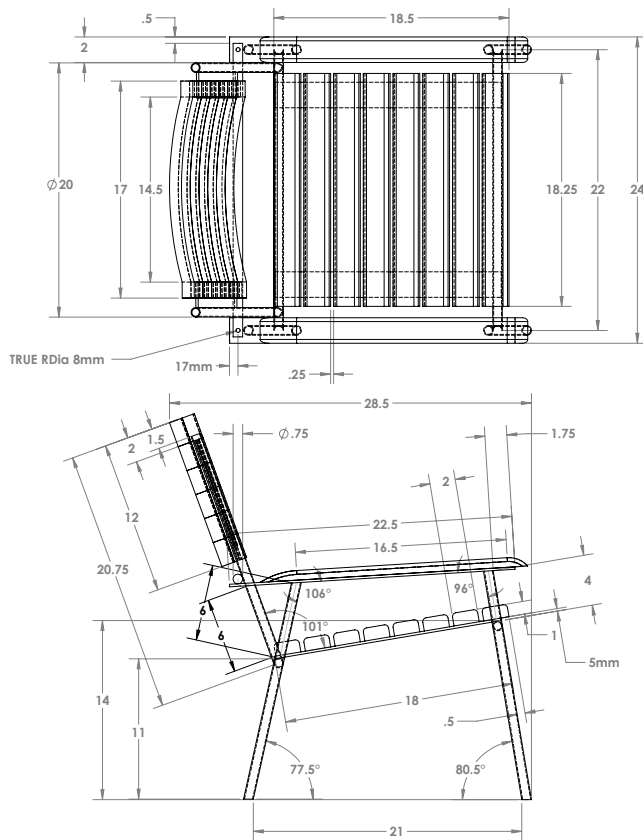

| ITEM NO. | PART | QTY. |
|----------|---|------|
| 1 | (5'X2')X3_RED SAL SOLID WOOD | 1 |
| 2 | 2' X1' RED SAL SOLID WOOD_(ARMREST) | 2 |
| 3 | 2'X1" RED SAL SOLID WOOD_(SEAT PLANKS) | 8 |
| 4 | DIA 0.75" 16 GAUGE_MS PIPE ROUND_(BACK VERTICAL MEMBER) | 2 |
| 5 | 2'X5MM_MS FLAT_(BACK VERTICAL) | 2 |
| 6 | DIA 0.75" 16 GAUGE_MS PIPE ROUND_(BACK HORIZONTAL MEMBER) | 1 |
| 7 | 2'X5MM_MS FLAT_(ARMREST) | 2 |
| 8 | DIA 0.75" 16 GAUGE_MS PIPE ROUND_(LEG-BACK) | 2 |
| 9 | 2'X5MM_MS FLAT_(SEAT RUNNER) | 2 |
| 10 | DIA 0.75" 16 GAUGE_MS PIPE ROUND_(SEAT MEMBER HORIZONTAL) | 2 |
| 11 | DIA 0.75" 16 GAUGE_MS PIPE ROUND_(LEG-FRONT) | 2 |

PRODUCTION JOURNEY

BACKREST

Three pieces of wood were joined together and shaped to form the backrest.

1 JOIN



2 CLAMP



3 GROOVE



4 CHISEL

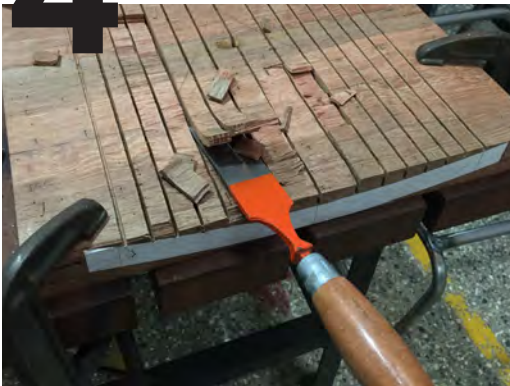

5 SHAPE



6 FINISH



STEEL FRAME

MS Pipes and Flats were used to create a stable frame for the chair.



For 7 & 8 Preferred method would be to powder coat instead of painting.



02

HAND MIXER

CONSUMER PRODUCT
Designing a conceptual
hand mixer with a focus
on form development.

1 WEEK

CONCEPT DEVELOPMENT

Exploration of various methods of lifting and resting the hand mixer. Considering natural mapping and ergonomics. Form follows function for this design.

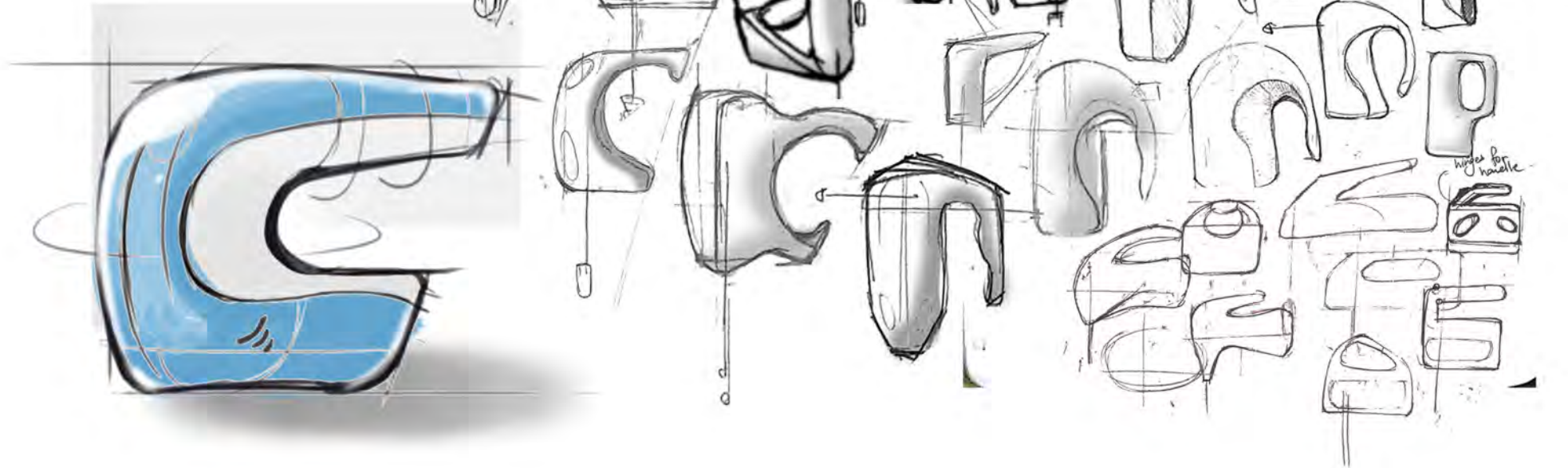

RESTING POSITION

Comfortable resting position. Easy to pick up where you left off. Unlike most hand mixers which have to be kept sideways



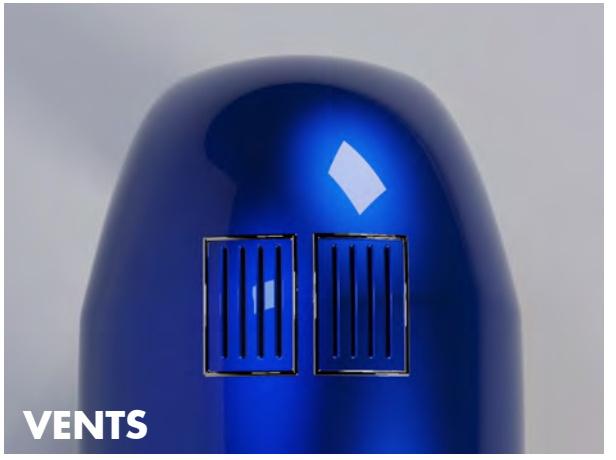

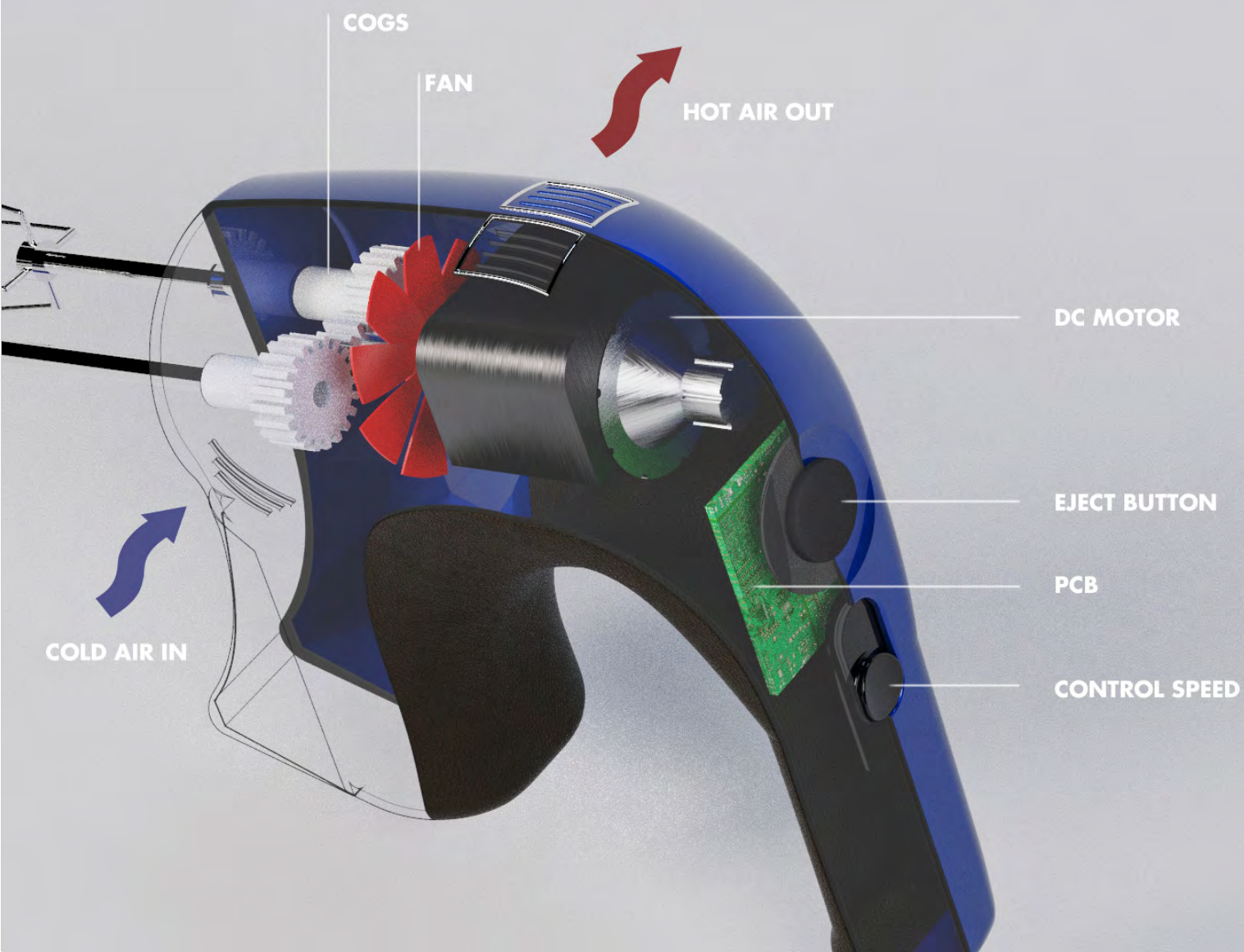

WHAT CHANGES INSIDE?

The orientation of the insides has shifted from horizontal to vertical. To accommodate this, the regular worm gear drive will have to be replaced with spur gears as there is no change in axes of motion.

03

**FLOAT
SIDE TABLE**

FURNITURE DESIGN

1 WEEK



SEEMS IMPOSSIBLE?

CONCEPT NOTE

We humans have always been fascinated with that which is mysterious and magical. In a world of mass production and optimization of everything we create, It can get a little dull at times. We appreciate things that take effort to create. The float side table is an attempt at recreating some of that mystery, magic and effort.



HERE'S HOW IT'S POSSIBLE

Concealing the metal structure
creatively to create an illusion.
Creating mystery by puzzling the
viewers.



04

PACKAGING

Redesigning existing packaging of moisturizing cream Nivea Soft, to make it more immersive and interesting, all the while following brand guidelines.

1 WEEK



ASPAC HONORABLE AWARD
(Asian Students Packaging Design Competition)
Exhibited: Good Design Marounochi
TOKYO



FORM DEVELOPMENT

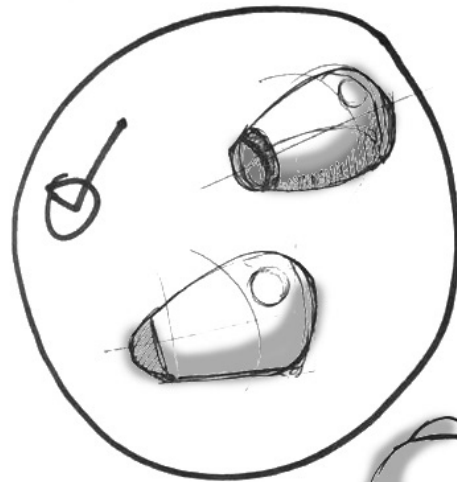
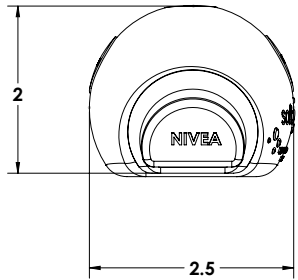
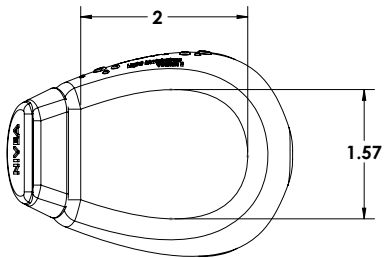
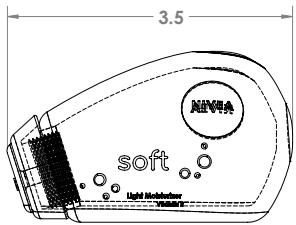
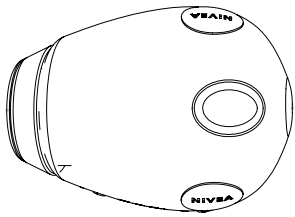

tip is useful.

comfortable grip

organic.

Base for placement.

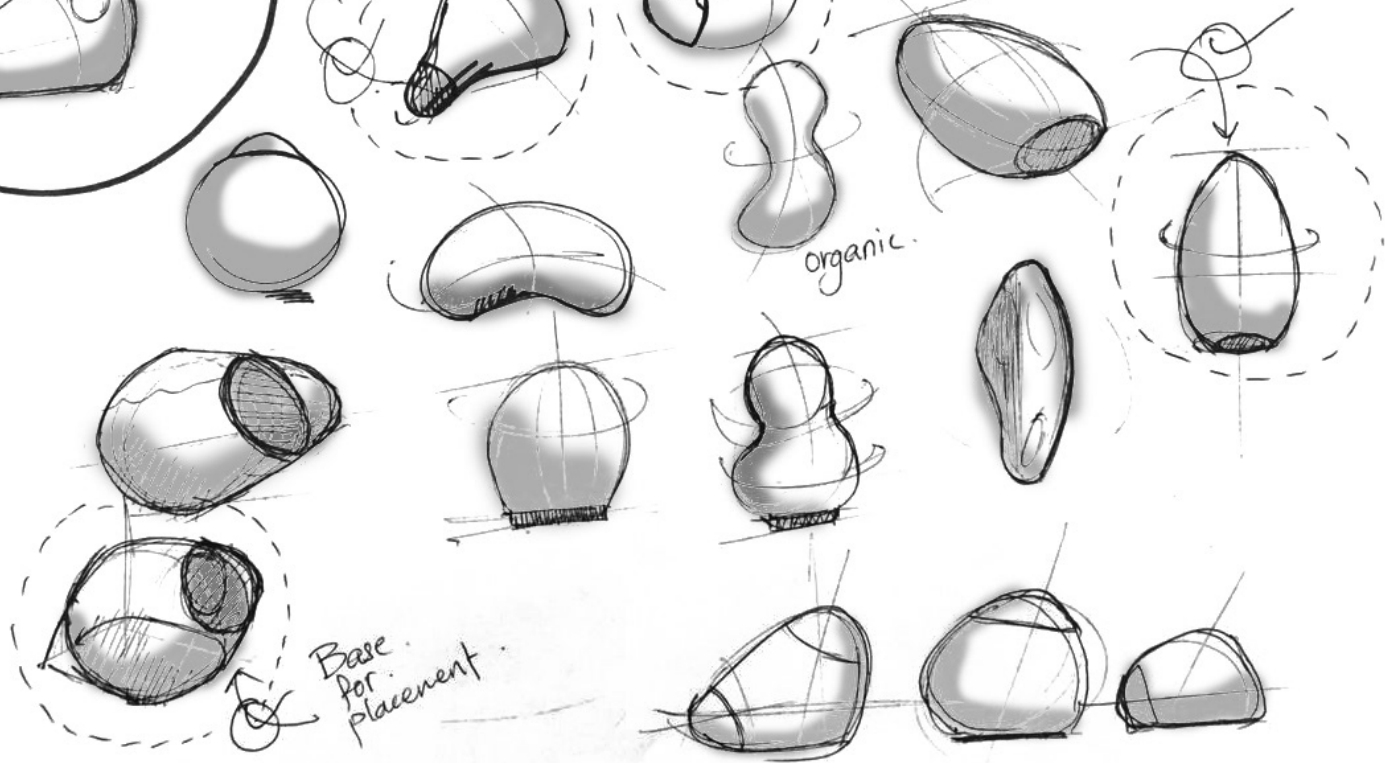

3D PRINTING & PROTOTYPING

CONCEPT

Nivea Soft is a moisturizing cream with a wide demographic. In this packaging the brand values have been followed to create a product/ packaging that brings out the qualities of the product itself.

It has a softer organic form to make it look visually softer than its similar product nivea creme which has different values.

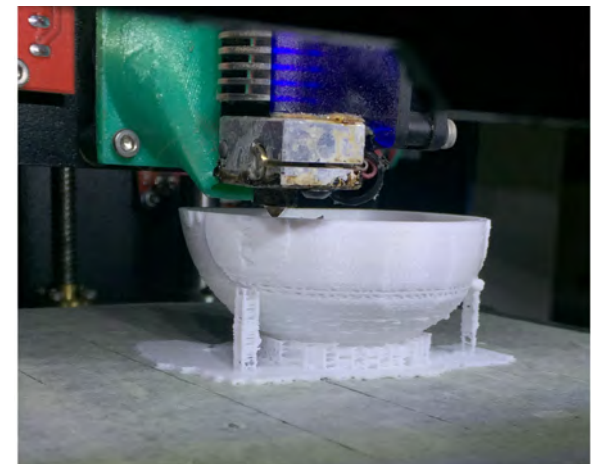
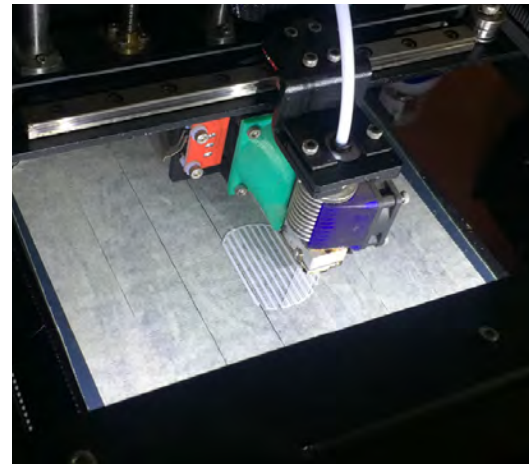

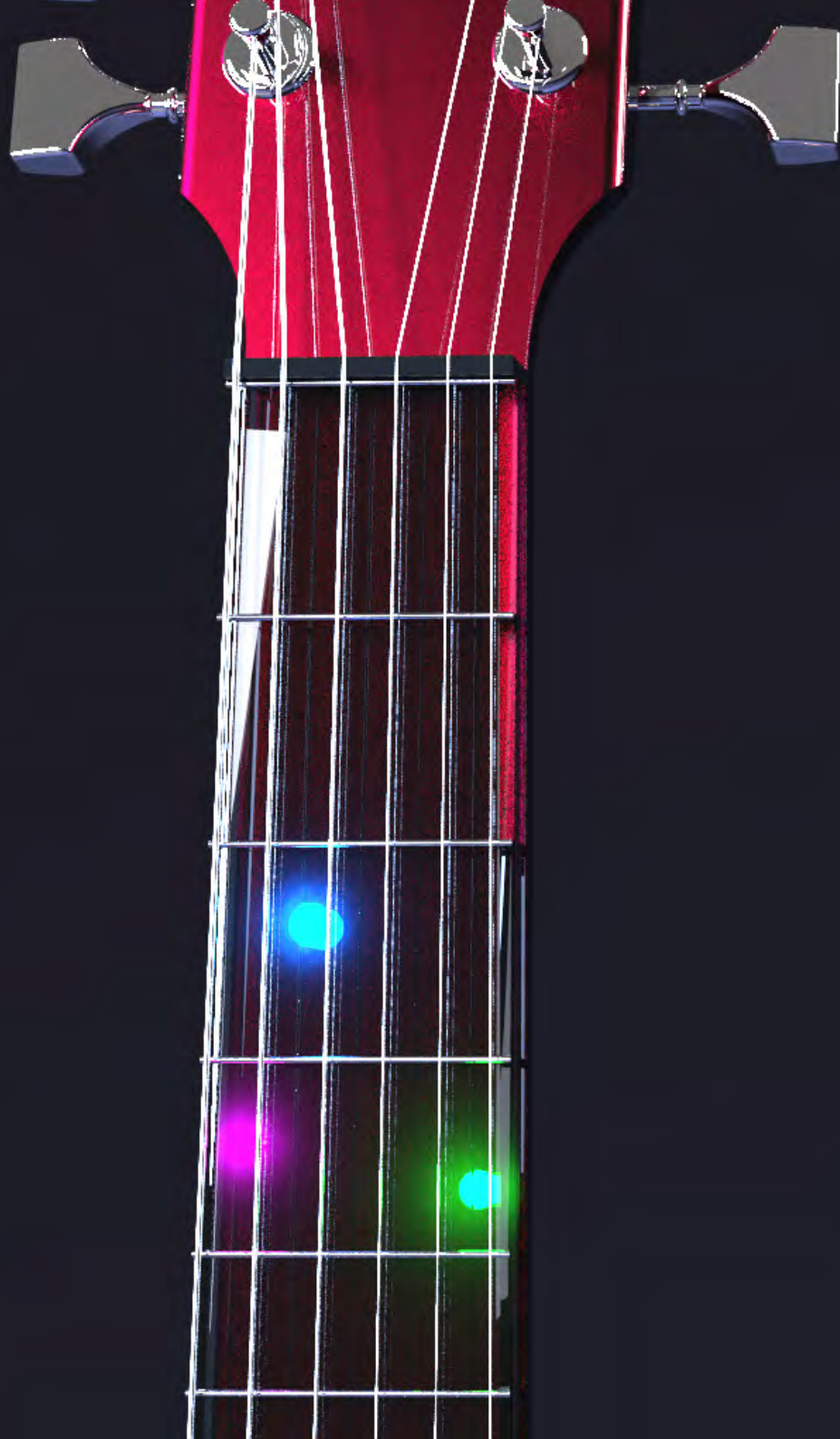

05

STRUM

self teaching

GUITAR

PRODUCT INNOVATION
Designing a Guitar that
aids in the teaching
process

GROUP PROJECT

1 WEEK

CONCEPT NOTE

Strum is a Guitar that teaches you how to play itself. It uses color coded LEDs in real time that help you navigate difficult chords while learning new songs. It is also a smart guitar that gives you feedback on your jamming sessions.

My Contribution

Ideating in a group
Concept development
Product Visualization
3d Modelling/Rendering
Prototyping with Electronics.

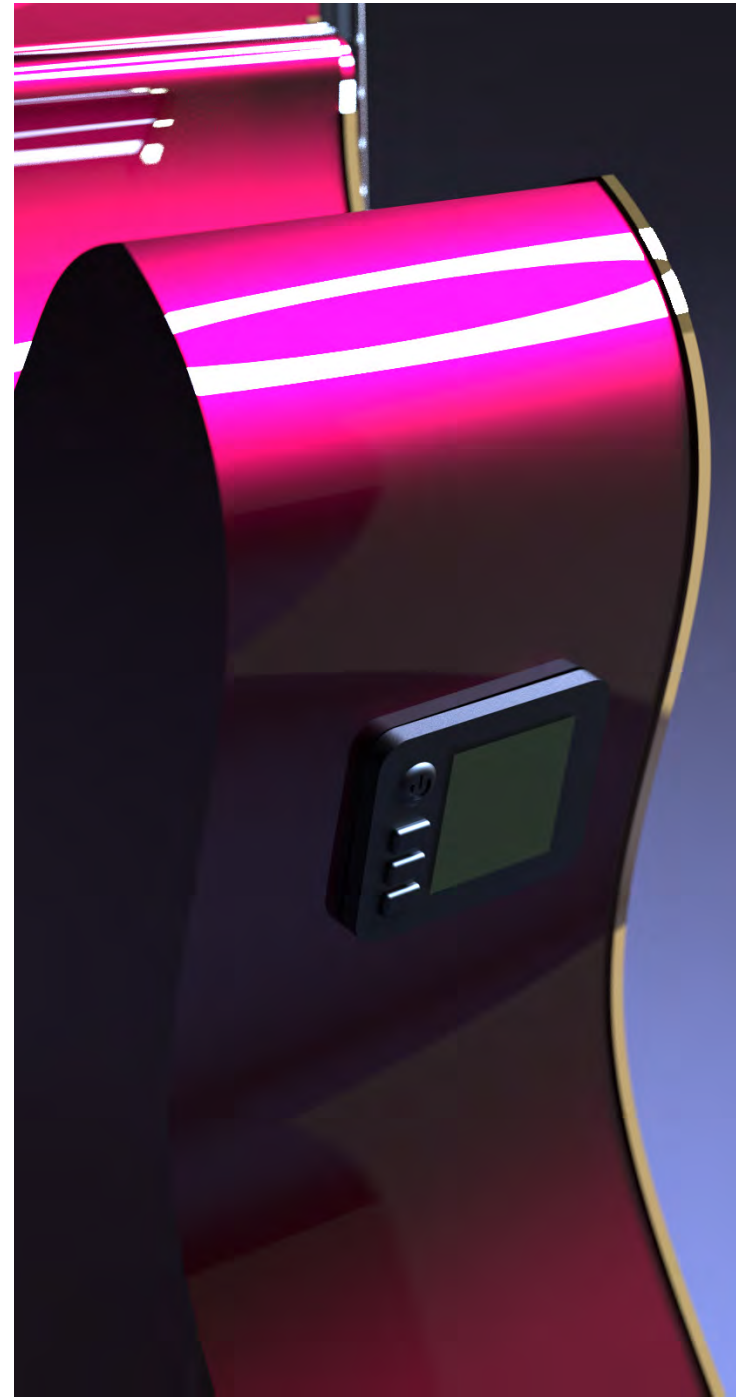
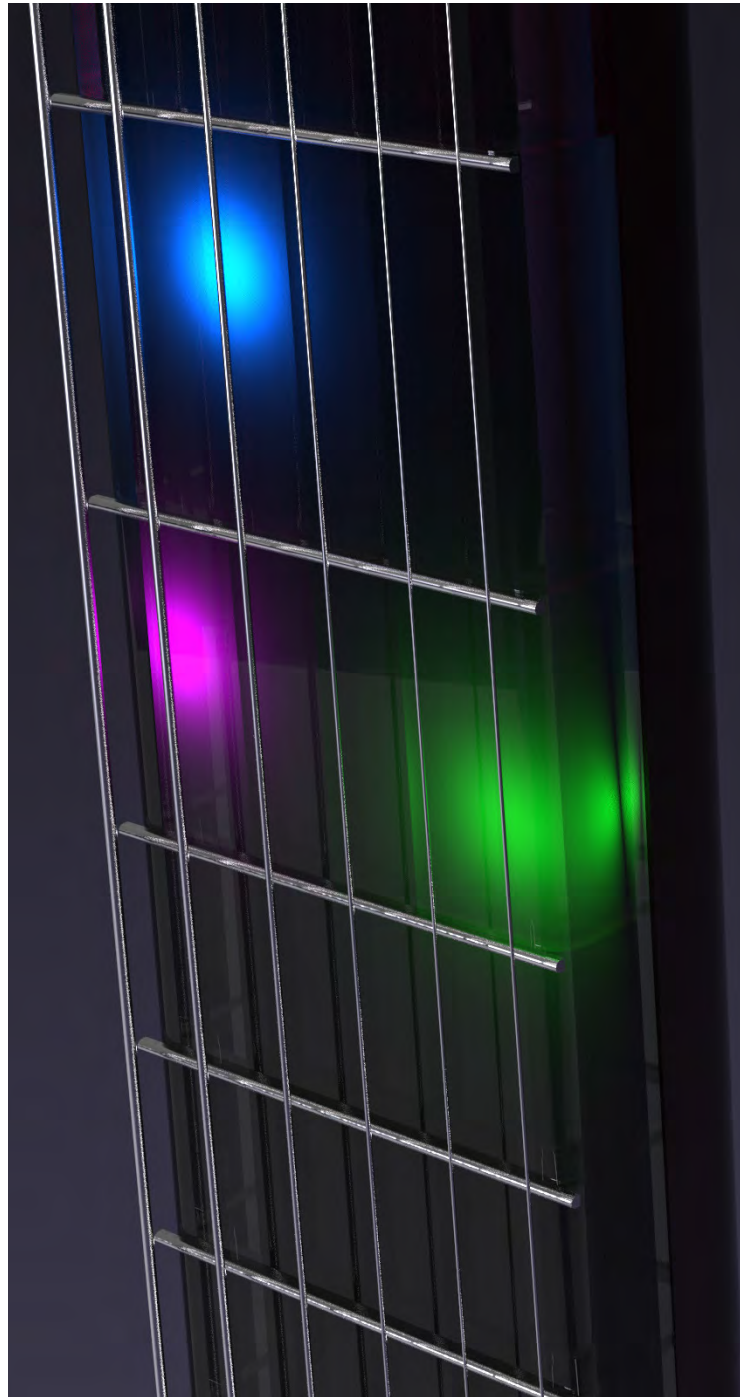

USER SCENARIO MAPPING



1. SWITCH GUITAR ON



2. IT CONNECTS AUTOMATICALLY TO YOUR PHONE VIA BLUETOOTH



3. OPEN THE STRUM APP ON YOUR PHONE AND CHOOSE A SONG TO PLAY



4. KEEP YOUR PHONE AWAY ON FOCUS ON THE GUITAR. LET THE LIGHTS GUIDE YOU.



5. VIEW YOUR STATS AND PERFORMANCE ON YOUR APP. IF NEEDED.



6. CHOOSE ANOTHER SONG FROM THE PHONE OR REPEAT.

PROBLEMS FACED BY ORDINARY GUITAR STUDENT

- **Eye hand co-ordination**
Looking at a chord chart and imitating on the fret board is difficult
- **Correct placement of fingers**
Guitar strings are of varied thickness and it takes a while to learn the correct way to hold and make a desirable sound.
- **Learning favourite song**
Players want to learn new songs even before learning music theory.



RAPID PROTOTYPING

USING

**ARDUINO UNO &
NEOPIXEL LEDs**



06

TELLURIAN DINING TABLE

FURNITURE DESIGN

Designing a dining table to help combat food waste.

2 WEEKS

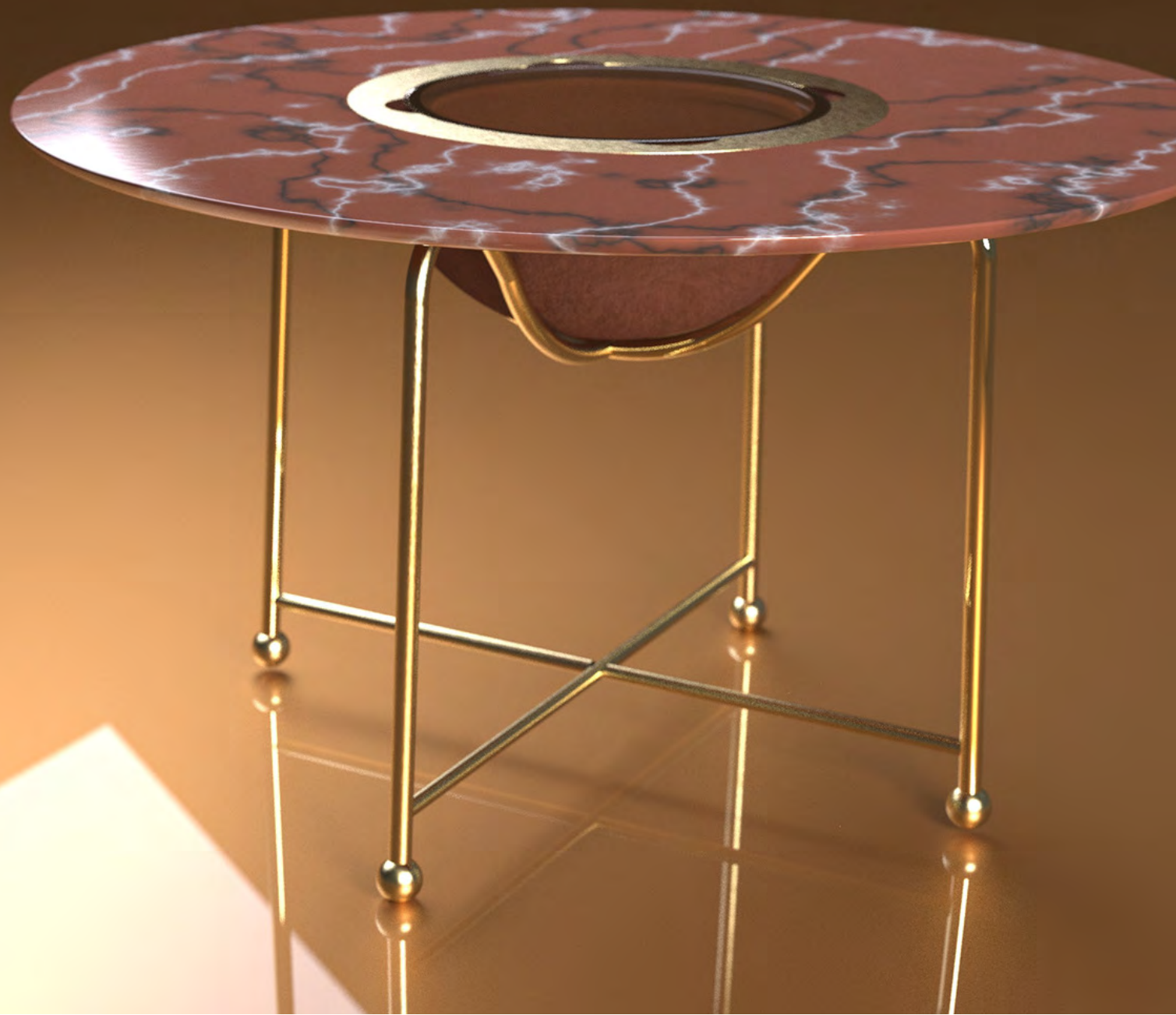

CONCEPT

"Tellurian" uses the concept of "Zeer" Pots to create a sustainable mini fridge to tackle food wastage.

The center of the table is made from terracotta & keeps the food cool and fresh. A glass top makes it visible for you to keep track of what food you have left so you don't waste any.



"Refrigerators are a leading cause of food wastage.

Every year the fridges keep getting larger and we store more food and end up wasting it after not realizing its been there." - *Dr. Layla Acaroglu*

Even though this version is made for the luxury market, the concept of the table can be easily replicated with other cheaper materials for a widespread use. Marble could be easily substituted with wood, steel & other stones

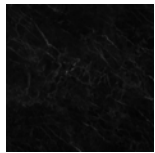

BLACK
MARBLE 435

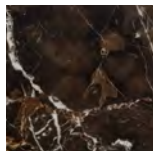

BROWN
MARBLE 835

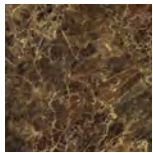

EMPERADOR
MARBLE

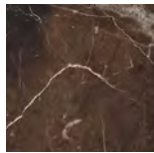

IRISH BROWN
MARBLE

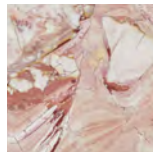

PINK MARBLE

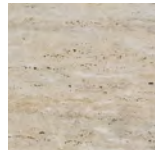

TRAVERTINE
MARBLE

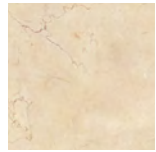

CREAM MARFIL
MARBLE

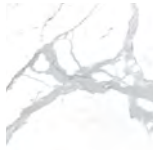

CALCUTTA
MARBLE 135



CARRARA
MARBLE 335

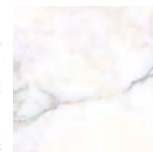

WHITE
MARBLE 535

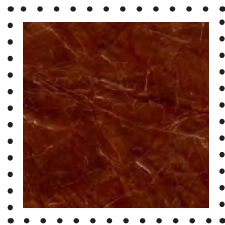

**RED
MARBLE
ROJO
ALICANTE**





**A GLANCE AT
SOME OTHER
PROJECTS**

FIN.

SKAND SHEKATKAR

skandshekatkar@gmail.com