

MAXINE SEETHAL

UNDERGRADUATE ARCHITECTURE PORTFOLIO

CIRRICULUM VITAE



EDUCATION:

2001-2016 - EPWORTH SCHOOL

IEB NATIONAL SENIOR CERTIFICATE (NSC)

SUBJECTS -

1. ENGLISH
2. ISIZULU
3. MATHEMATICS
4. HISTORY
5. VISUAL ARTS
6. FRENCH
7. LIFE ORIENTATION
8. ADVANCED PROGRAM ENGLISH

2017-2019 - UNIVERSITY OF CAPE TOWN

BACHOLOR OF ARCHITECTURAL STUDIES (BAS)

LANGUAGE PROFICENY:

ENGLISH ●●●●●
ISIZULU ●●●○○
FRENCH ●●●○○
AFRIKAANS ●●●●○

PROGRAM PROFICENECY:

MICROSOFT OFFICE ●●●●○
ADOBE PHOTOSHOP ●●●○○
ADOBE INDESIGN ●●○○○
REVIT ●●●●○
SKETCHUP ●●●●○
TWINMOTION ●●●●○
AUTOCAD ●●●●●
RHINO ●○○○○

PERSONAL DETAILS:

CEL: 0834112225

EMAIL: MAXINESEETHAL@GMAIL.COM

BIRTHDATE: 7 MAY 1998

ID NUMBER: 9805070128080

MARITAL STATUS: UNMARRIED

NATIONALITY: SOUTH AFRICAN

EXPERIENCE:

2015 - JOB SHADOWING AT MTHULISI MSIMANG

ARCHITECTS

2016/2017 - JOB SHADOWING AT ICA ARCHITECTS AND

URBAN DESIGNERS

2018 - JOB SHADOWING AT MR PRICE GROUP REAL

ESTATE DEPARTMENT

PERSONAL TRAITS

- HARD WORKING
- GOOD ORGANISATION SKILLS
- QUICK LEARNER
- COMMITED
- GOOD UNDER PRESSURE
- COOPERATIVE TEAM MEMBER

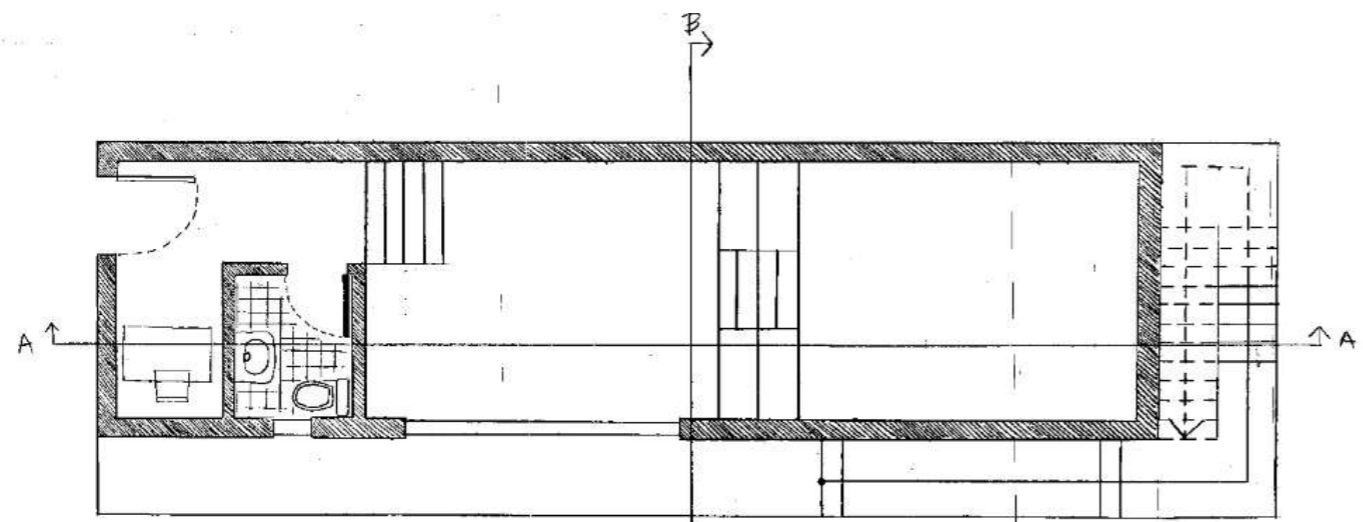

GROUND STOREY

THE GROUND STOREY, PUBLIC EXHIBITION SPACE WILL BE USED TO SHOWCASE VISUAL AND PERFORMING ART WORKS FROM THE EXPRESSIVE ARTS PROGRAM WHICH IS RUN BY THE DISTRICT 6 MUSEUM WHICH IS LOCATED A FEW METERS DOWN THE ROAD.

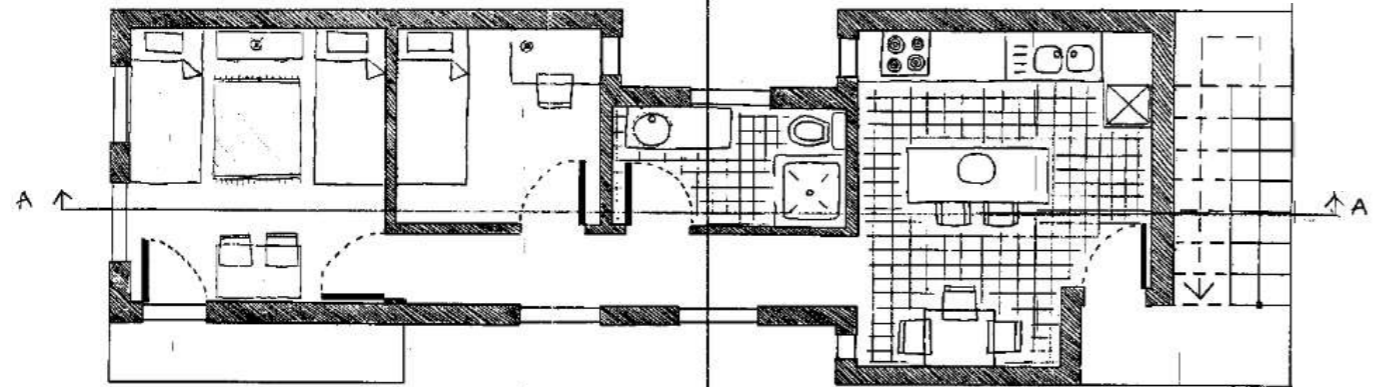

FIRST STOREY

THE FIRST STOREY, TWO BEDROOM ACCOMMODATION WILL BE OCCUPIED FOR TEMPORARY TIME PERIODS BY THREE HISTORIC OR ART STUDENTS WHO'S WORKS WILL BE SHOWCASED IN THE EXHIBITION SPACE ON THE GROUND FLOOR

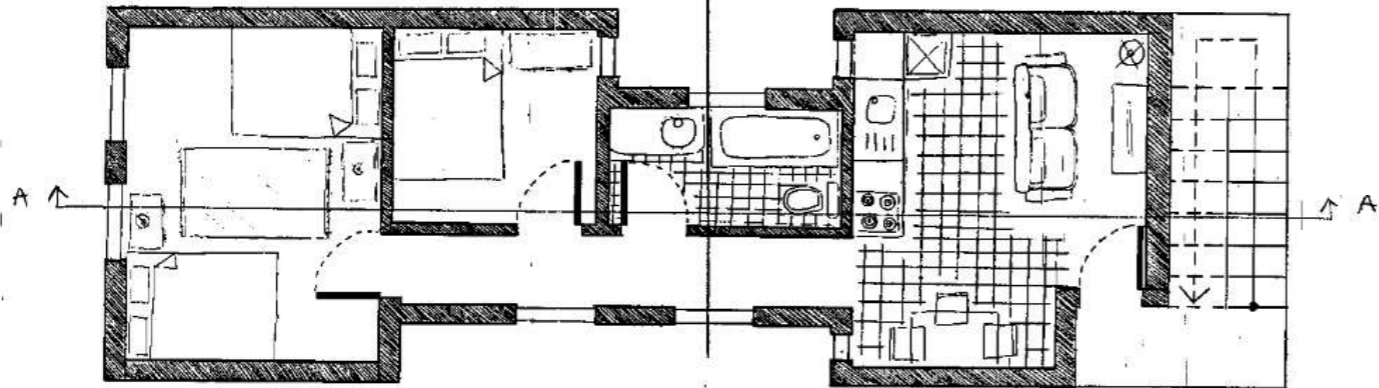

SECOND STOREY

THE SECOND STOREY, TWO BEDROOM ACCOMMODATION WILL BE OCCUPIED BY A FAMILY WHO ARE LOOKING TO STAY LONG-TERM. THE RESIDENTS WOULD IDEALLY BE EMPLOYERS FROM THE DISTRICT 6 MUSEUM WHICH IS LOCATED A FEW METERS DOWN THE ROAD, ALONG WITH THEIR CHILDREN.

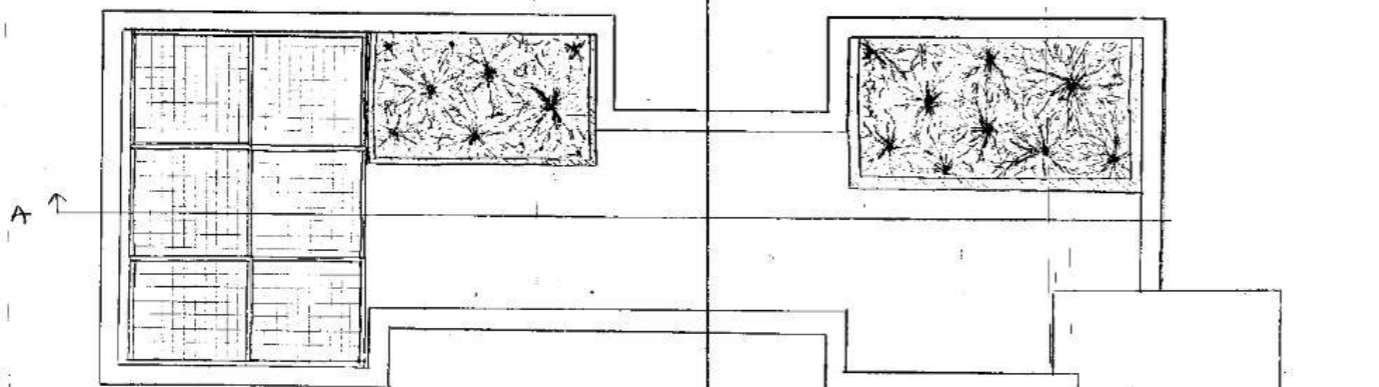

ROOF PLAN

THE ROOF TOP GARDEN IS ACCESSIBLE TO RESIDENTS WHO RESIDE ON THE FIRST AND SECOND STOREY.





CROSS-SECTION

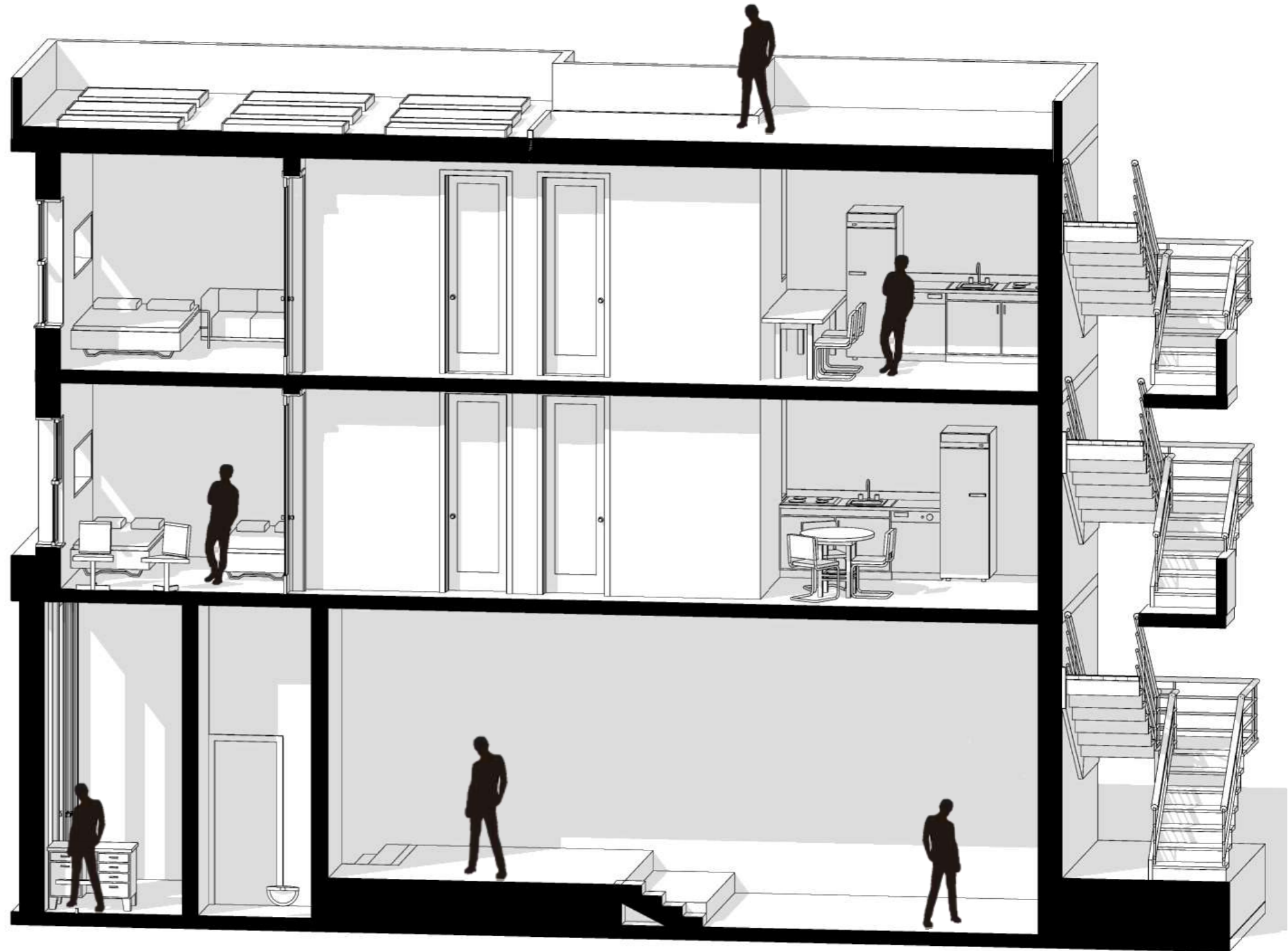

LONGITUDINAL SECTION





TECHNICAL DEVELOPMENT

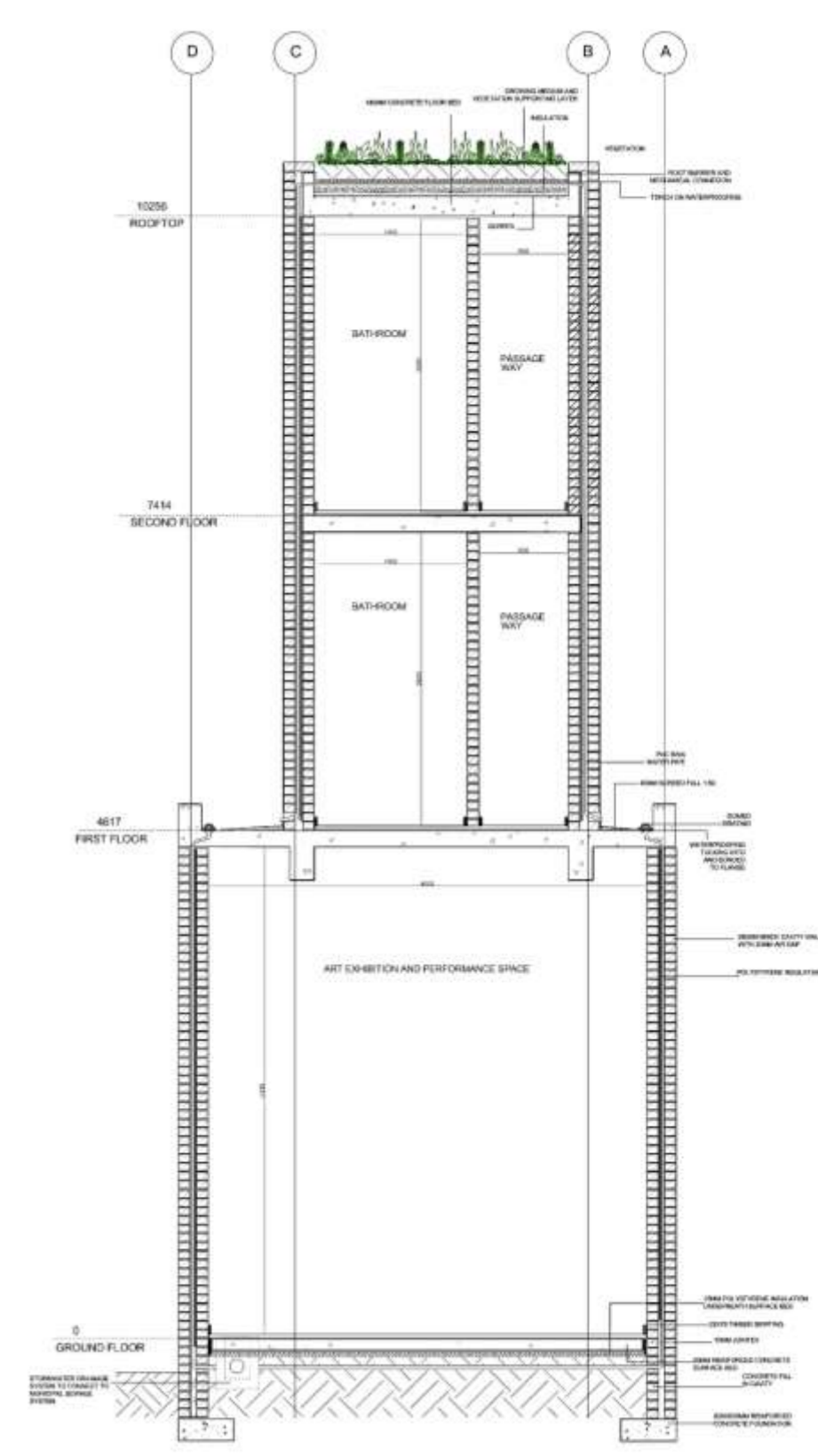
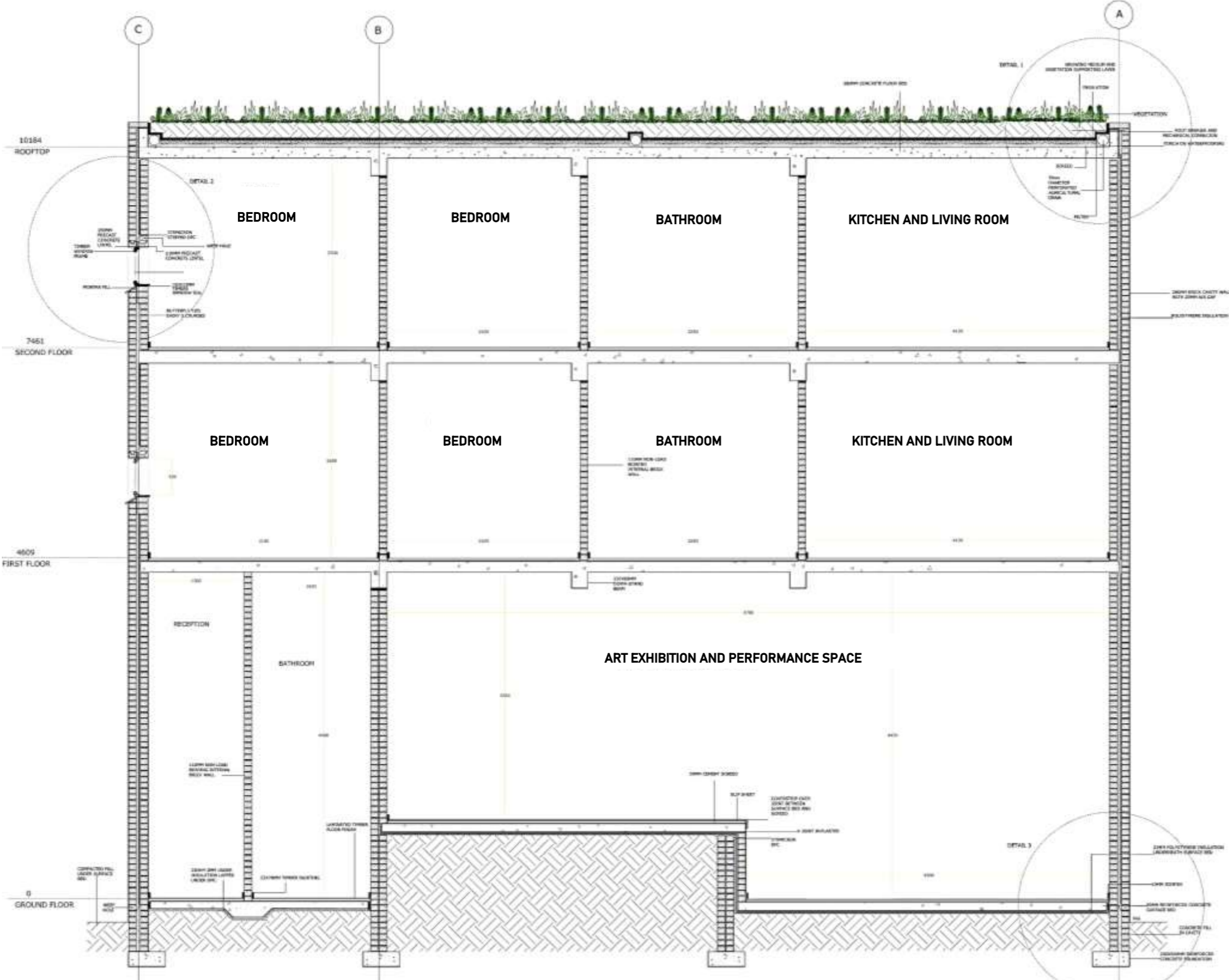

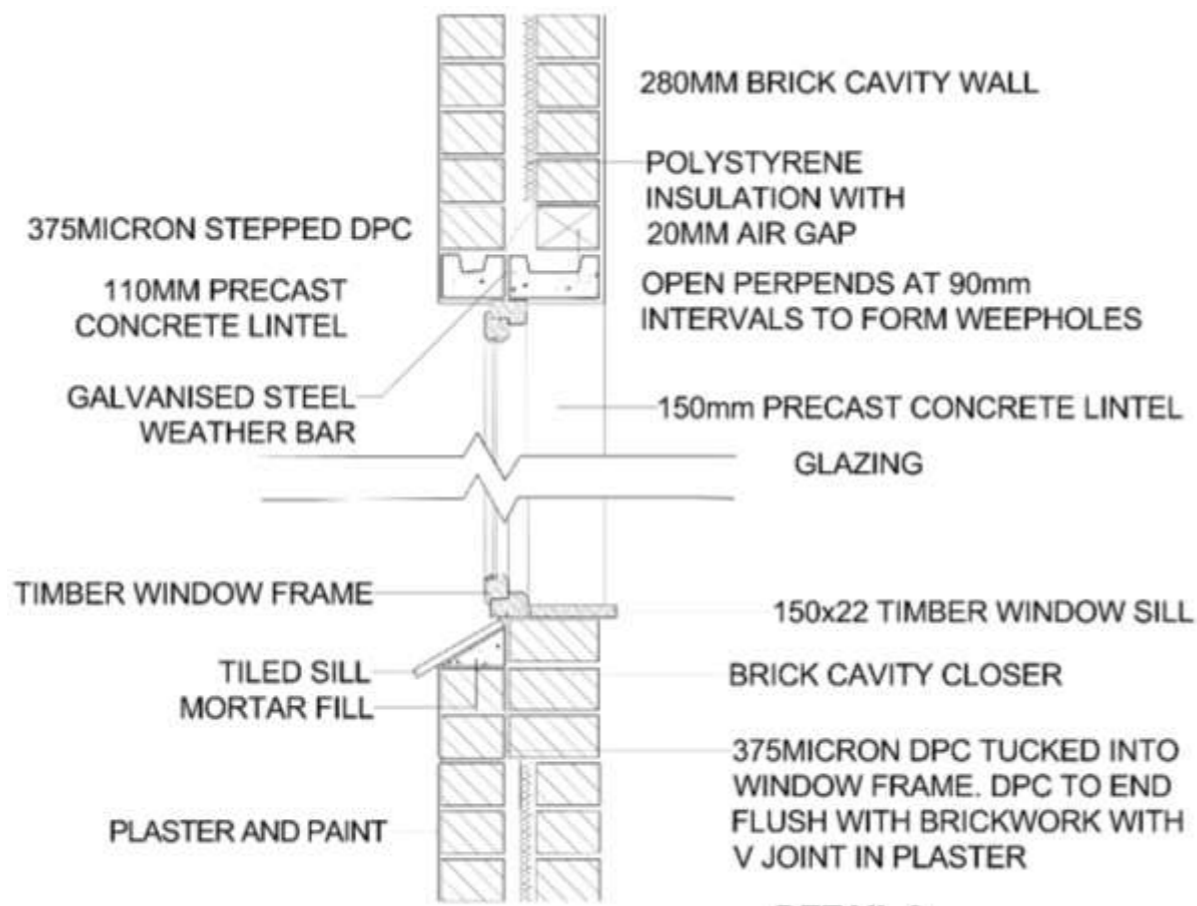

DETAIL 2
1:5

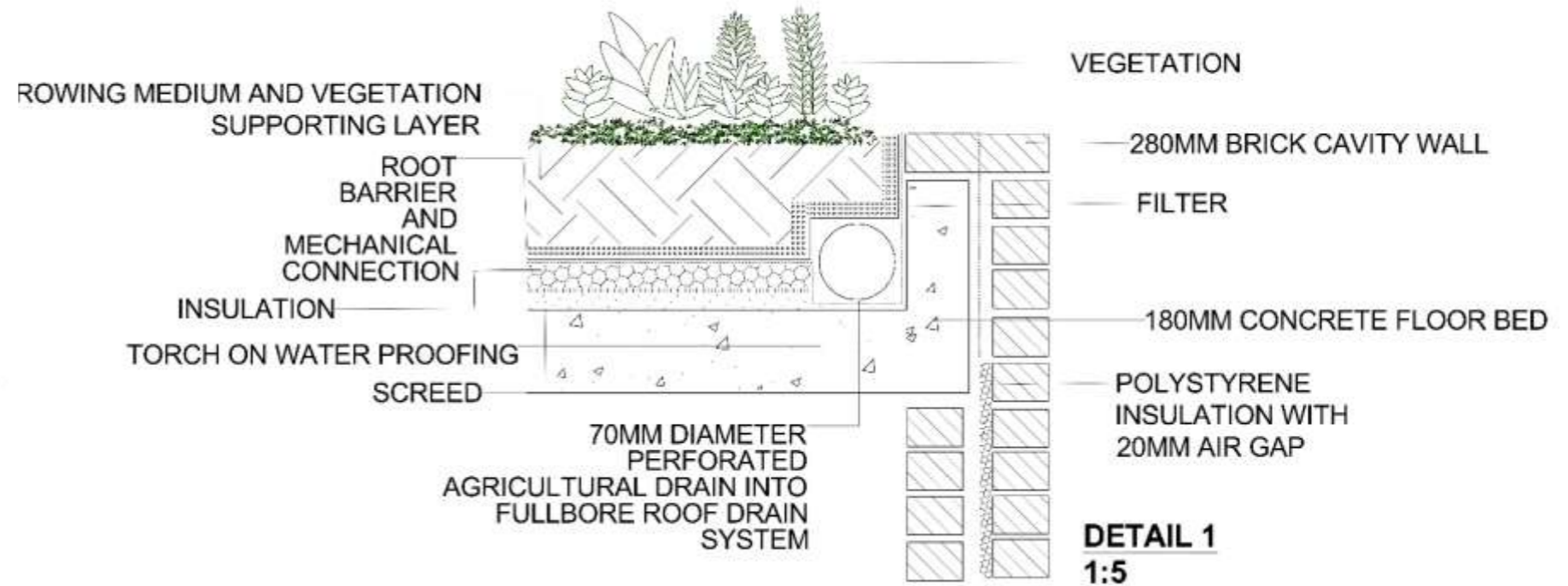

DETAIL 1
1:5

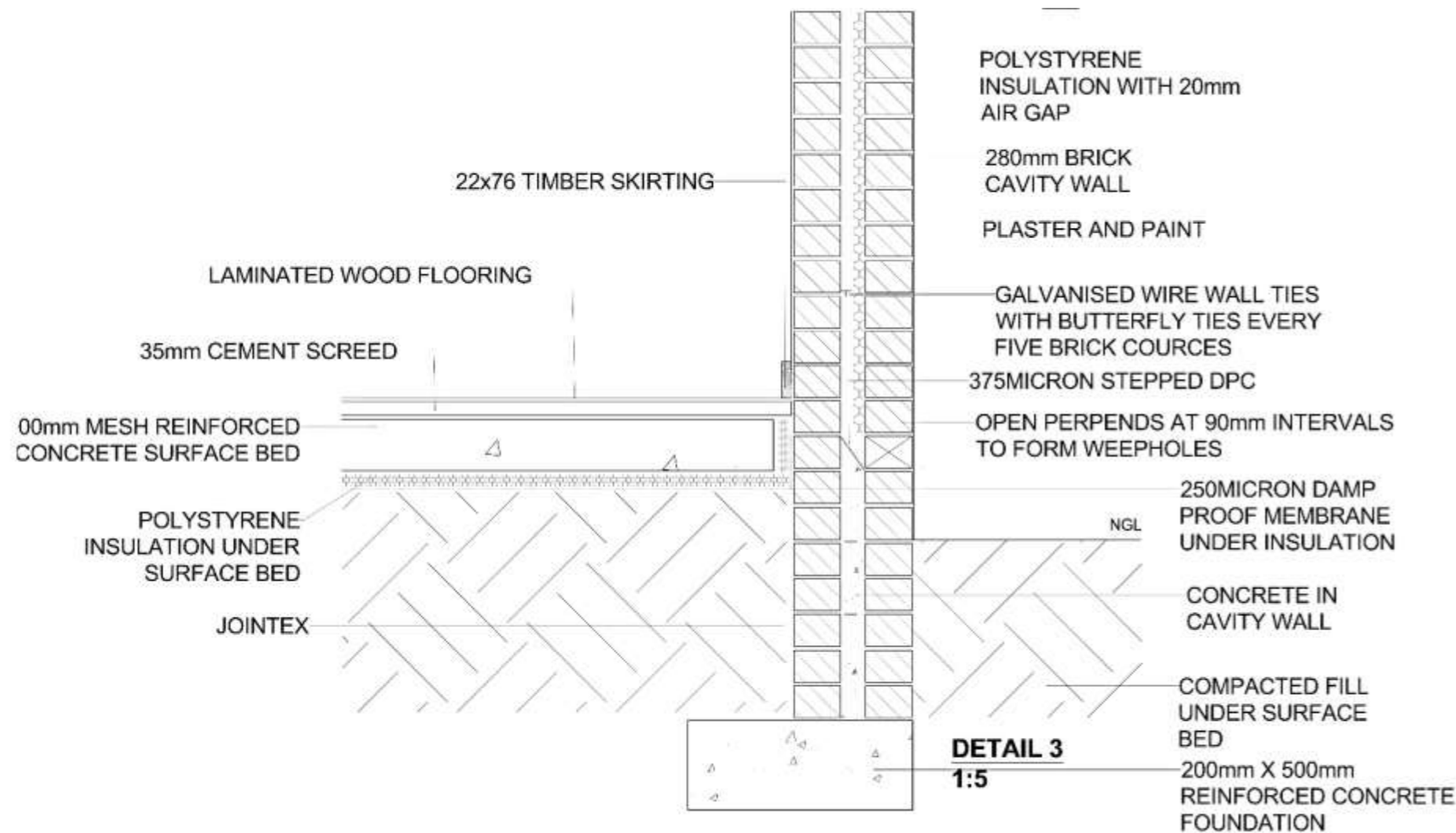

DETAIL 3
1:5

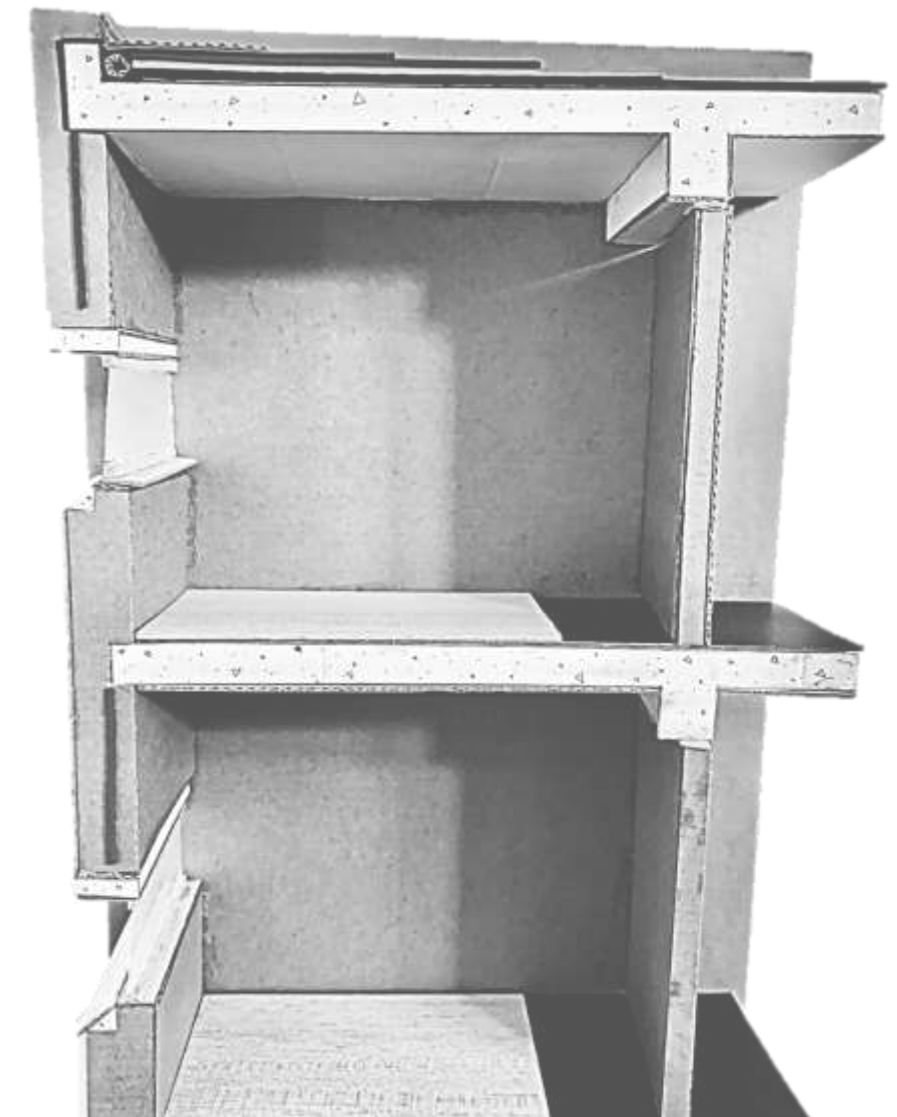

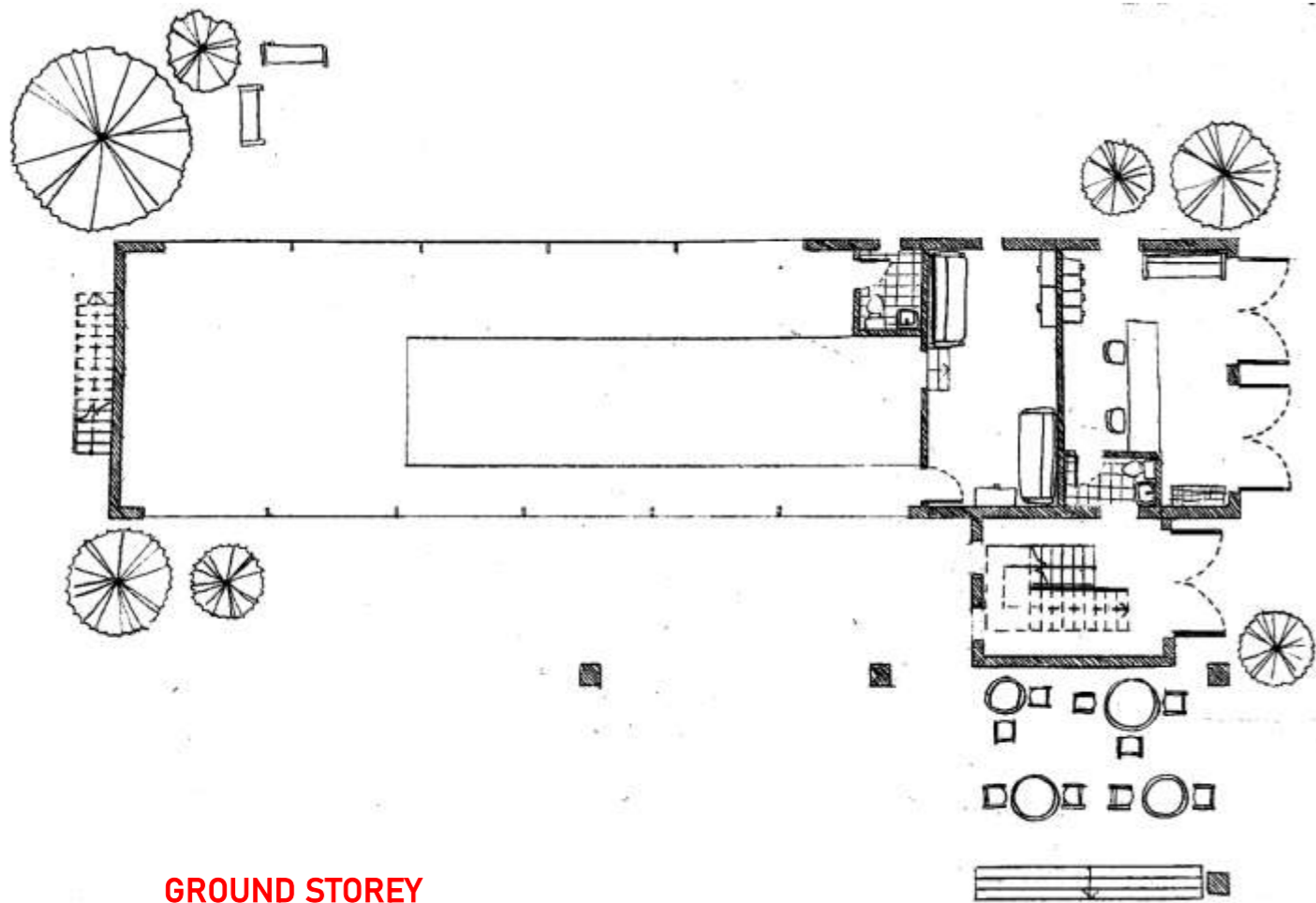

GROUND STOREY

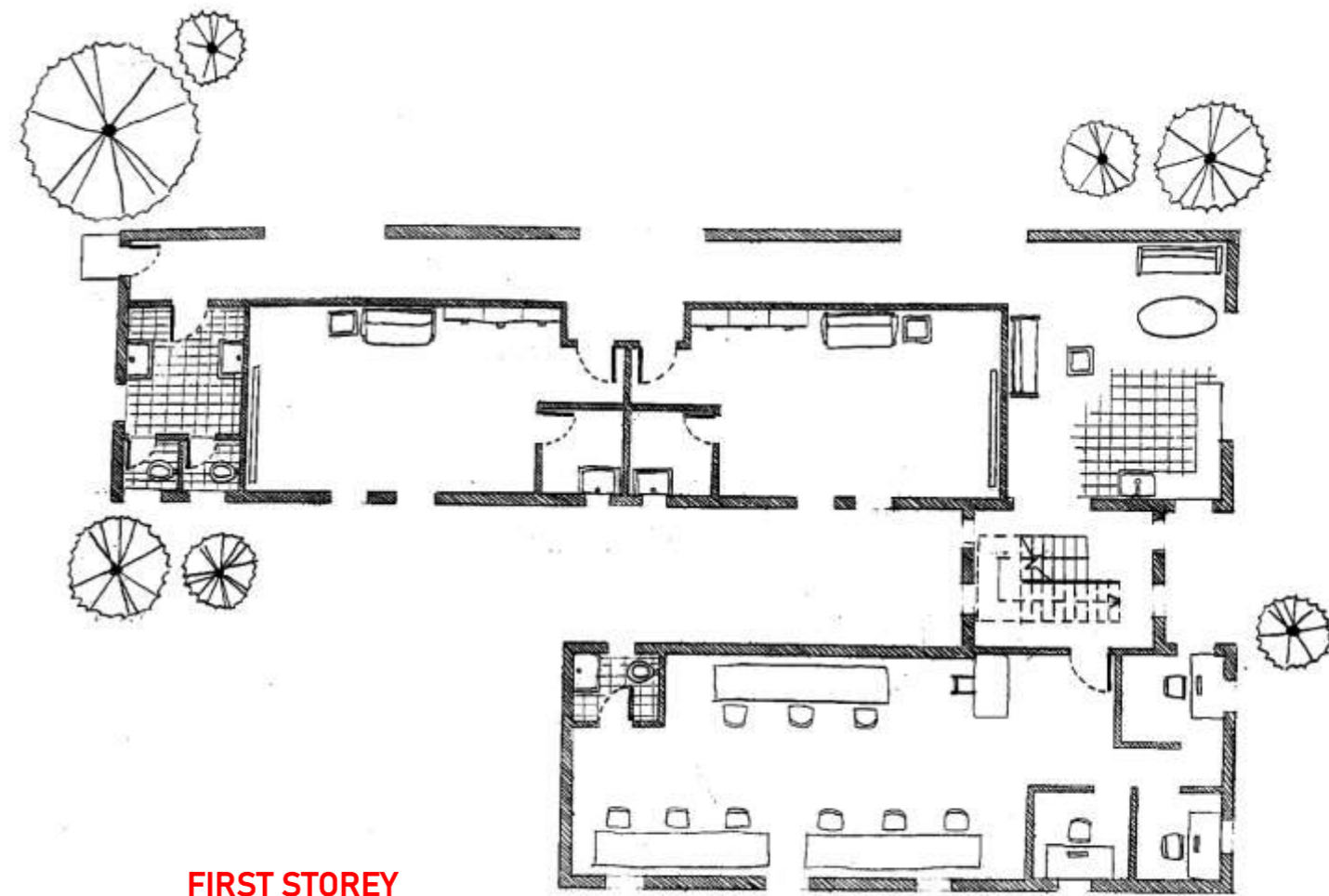

FIRST STOREY

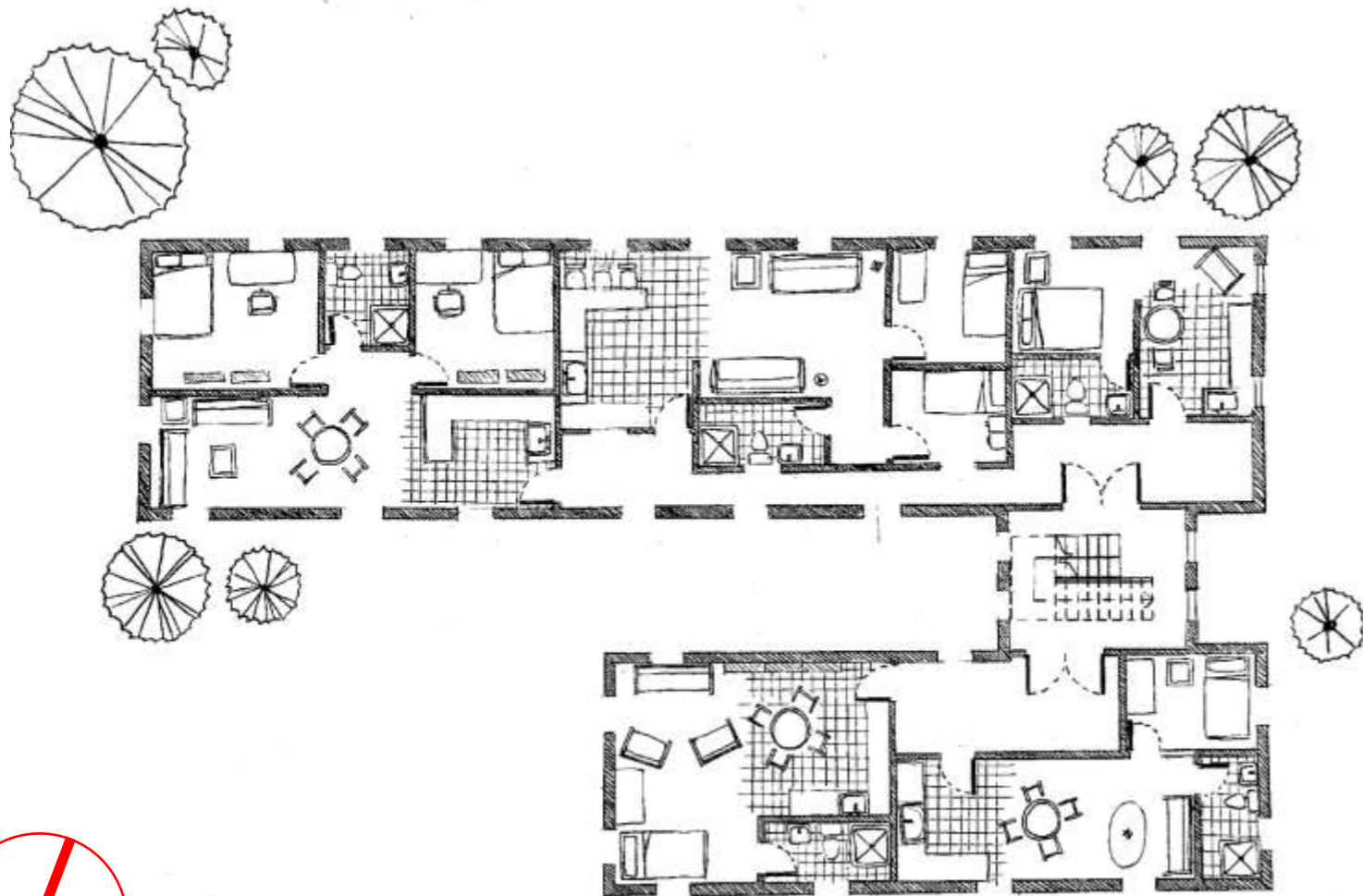

SECOND STOREY

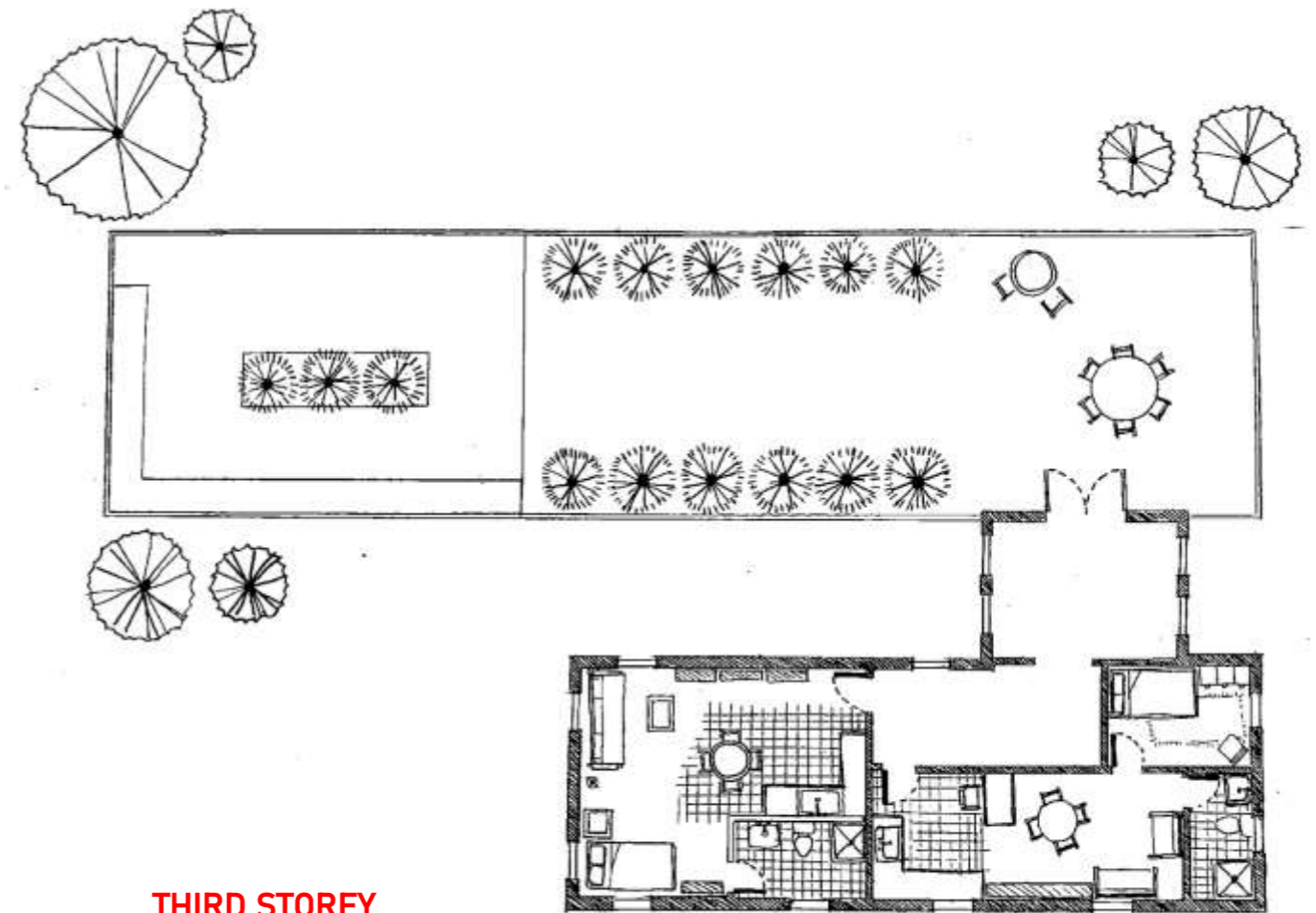

THIRD STOREY



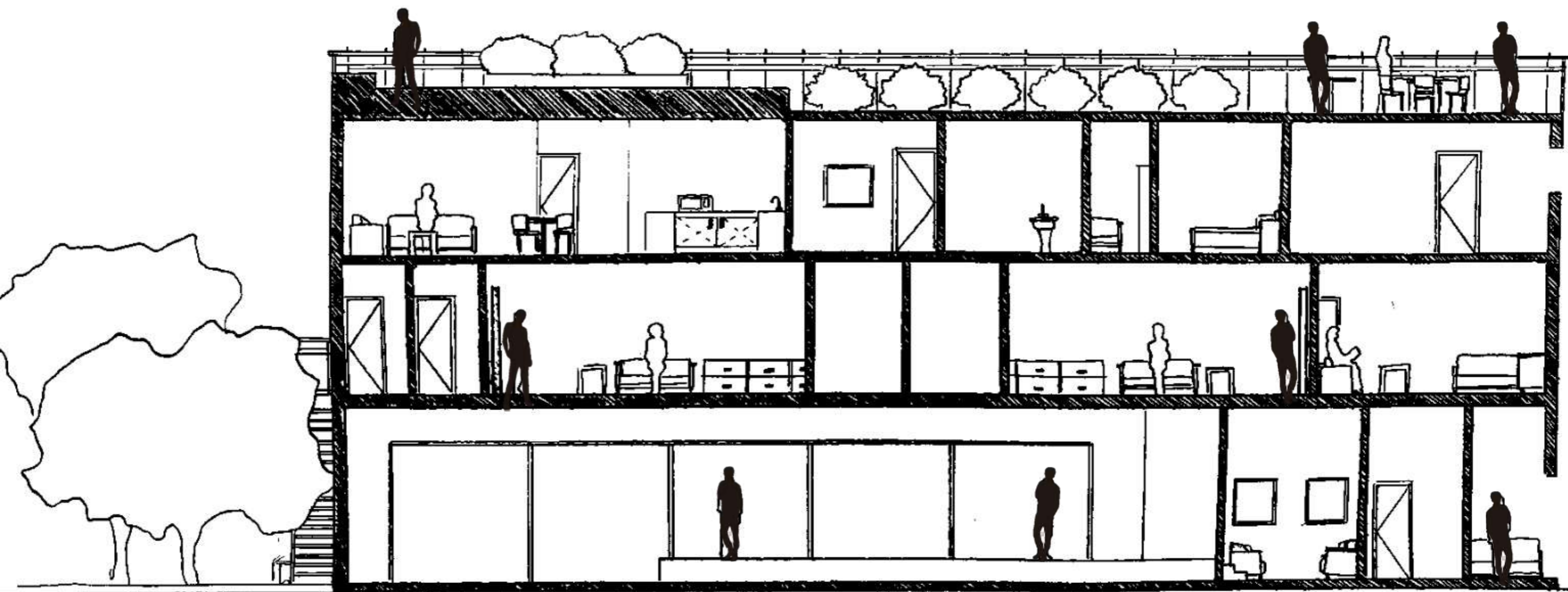

LONGITUDINAL SECTION

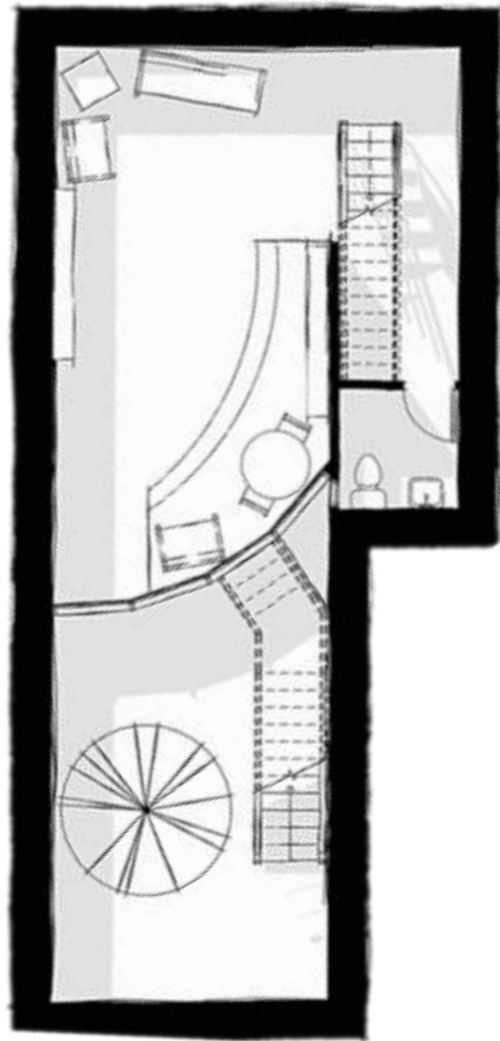

BASEMENT

COURTYARD AND LIBRARY SPACE FOR PUBLIC USE

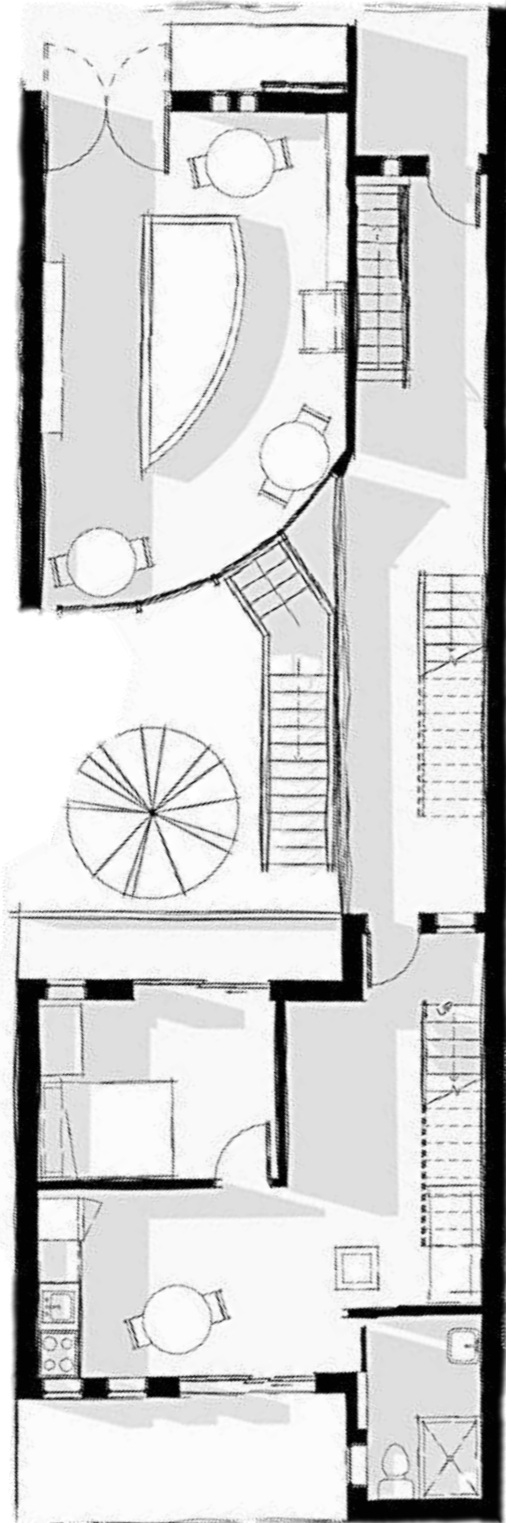

GROUND STOREY

LIBRARY FOR PUBLIC USE AND ONE BEDROOM ACCOMIDATION FOR PARTIALLY ABLED PERSON

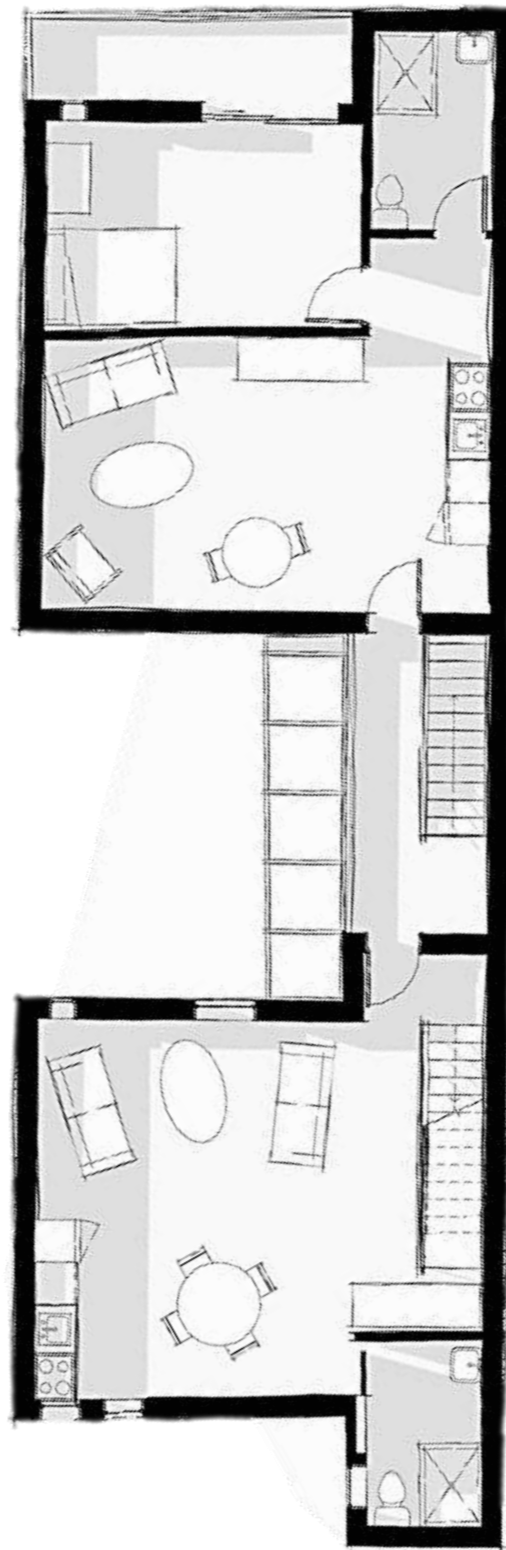

FIRST STOREY

PRIVATE, RENTABLE ONE BEDROOM ACCOMIDATOION AND LIVING ROOM SPACE WHICH IS SHARED BETWEEN ACCOMIDATION WHICH IS ABOVE AND BELOW IT.

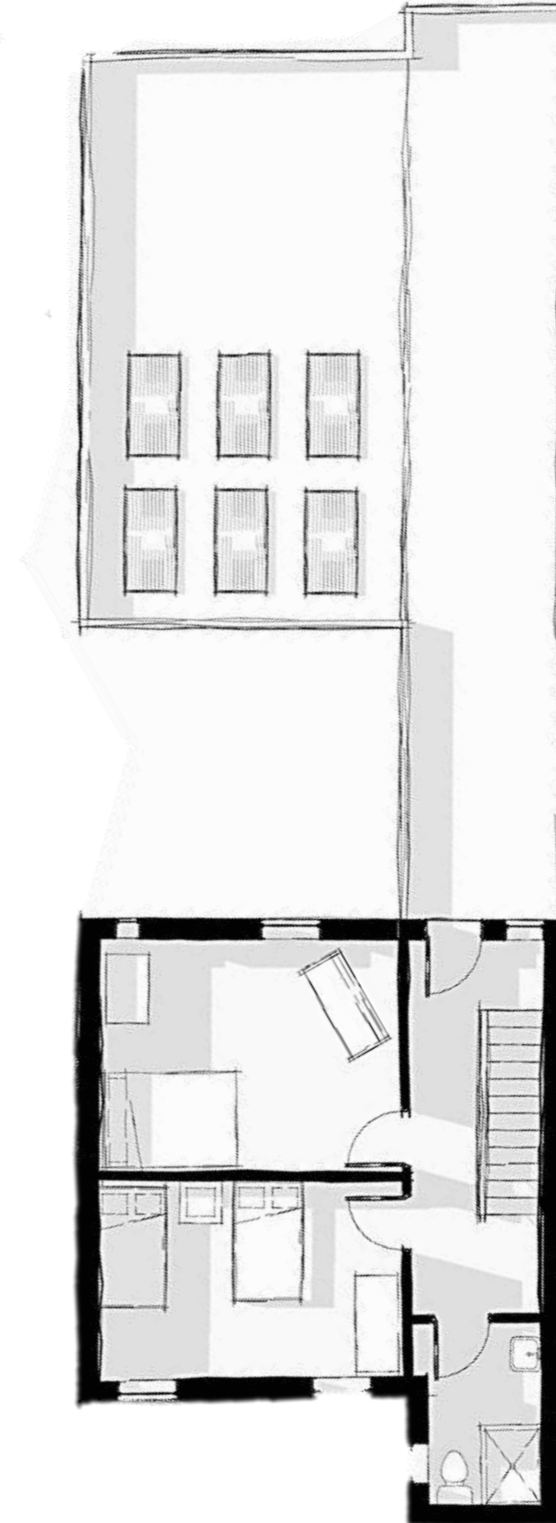

SECOND STOREY

ACCESSIBLE ROOFTOP GARDEN AND TWO BEDROOM ACCOMIDATION

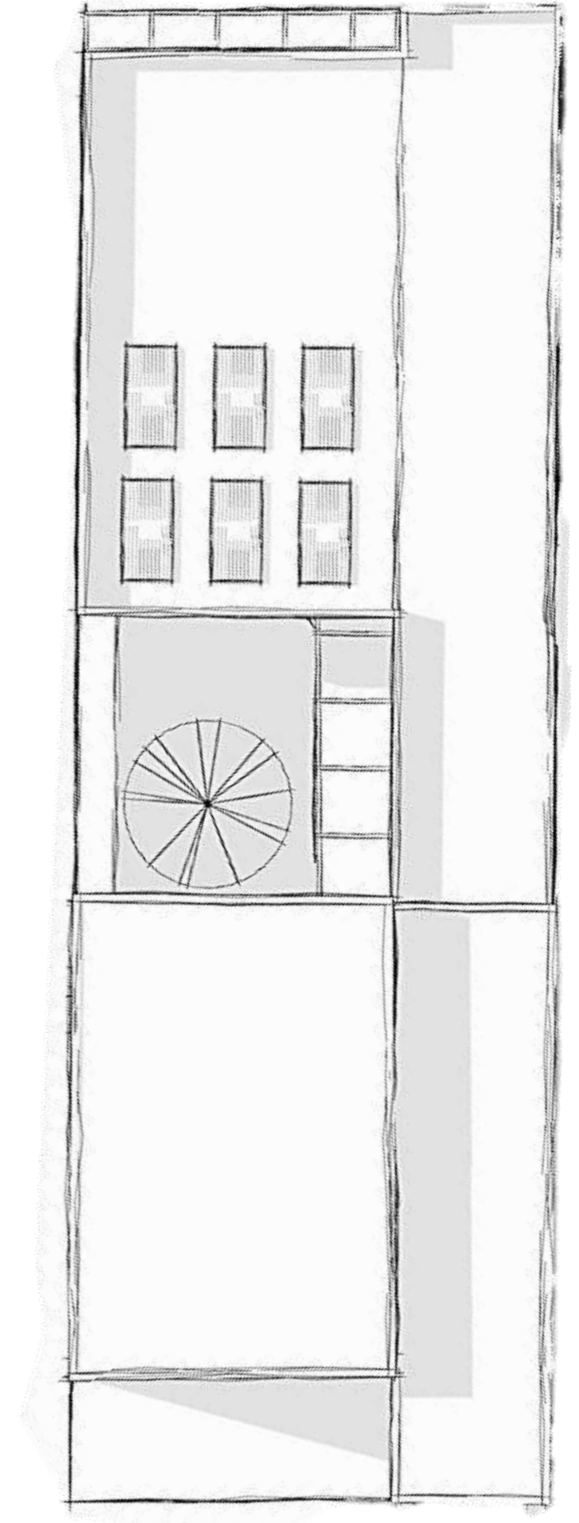

ROOF PLAN



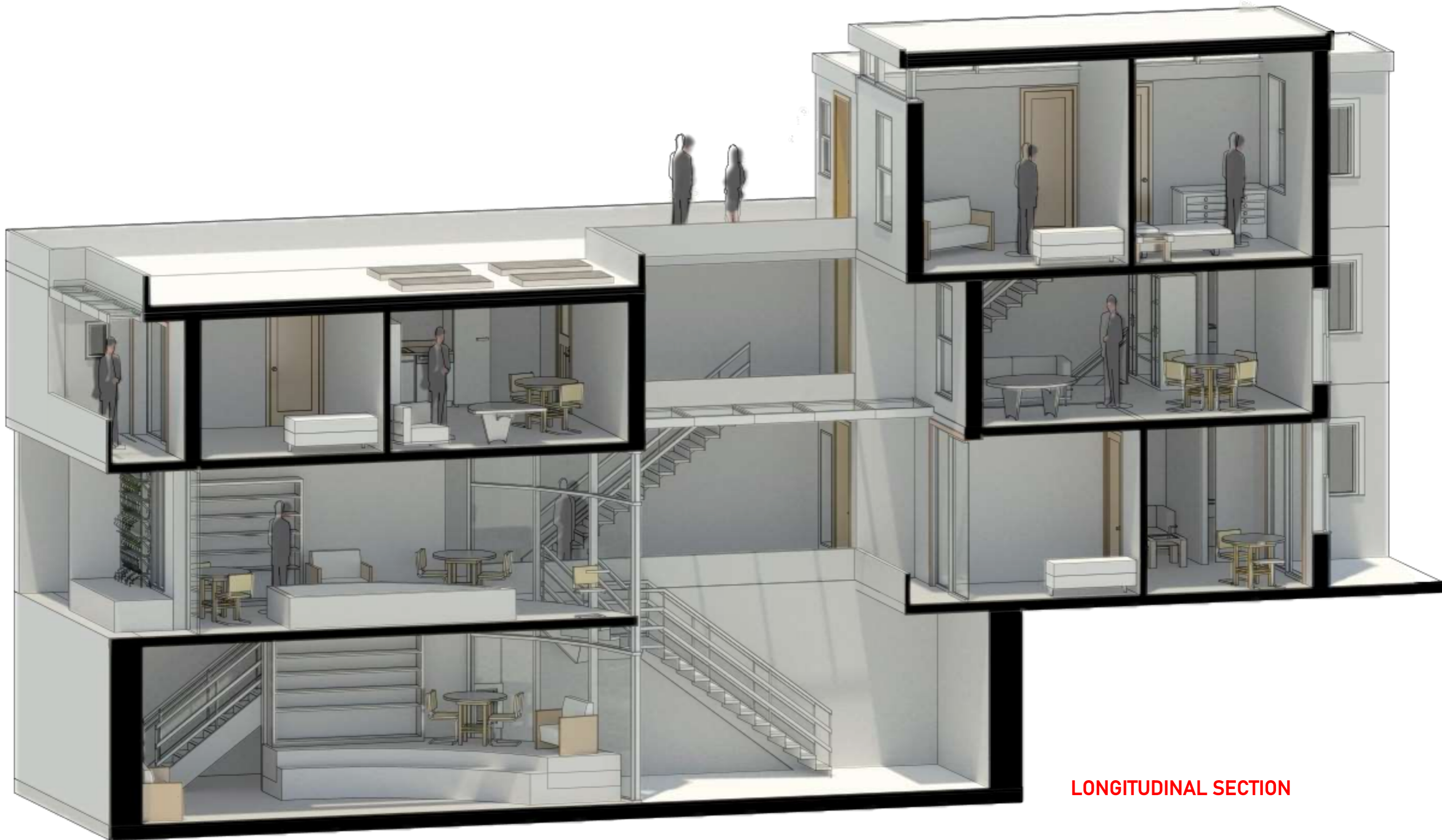

LONGITUDINAL SECTION



LONGITUDINAL SECTION







RENDERS OF LIBRARY AND COURTYARD SPACE WHICH ARE ACCESSIBLE TO THE PUBLIC

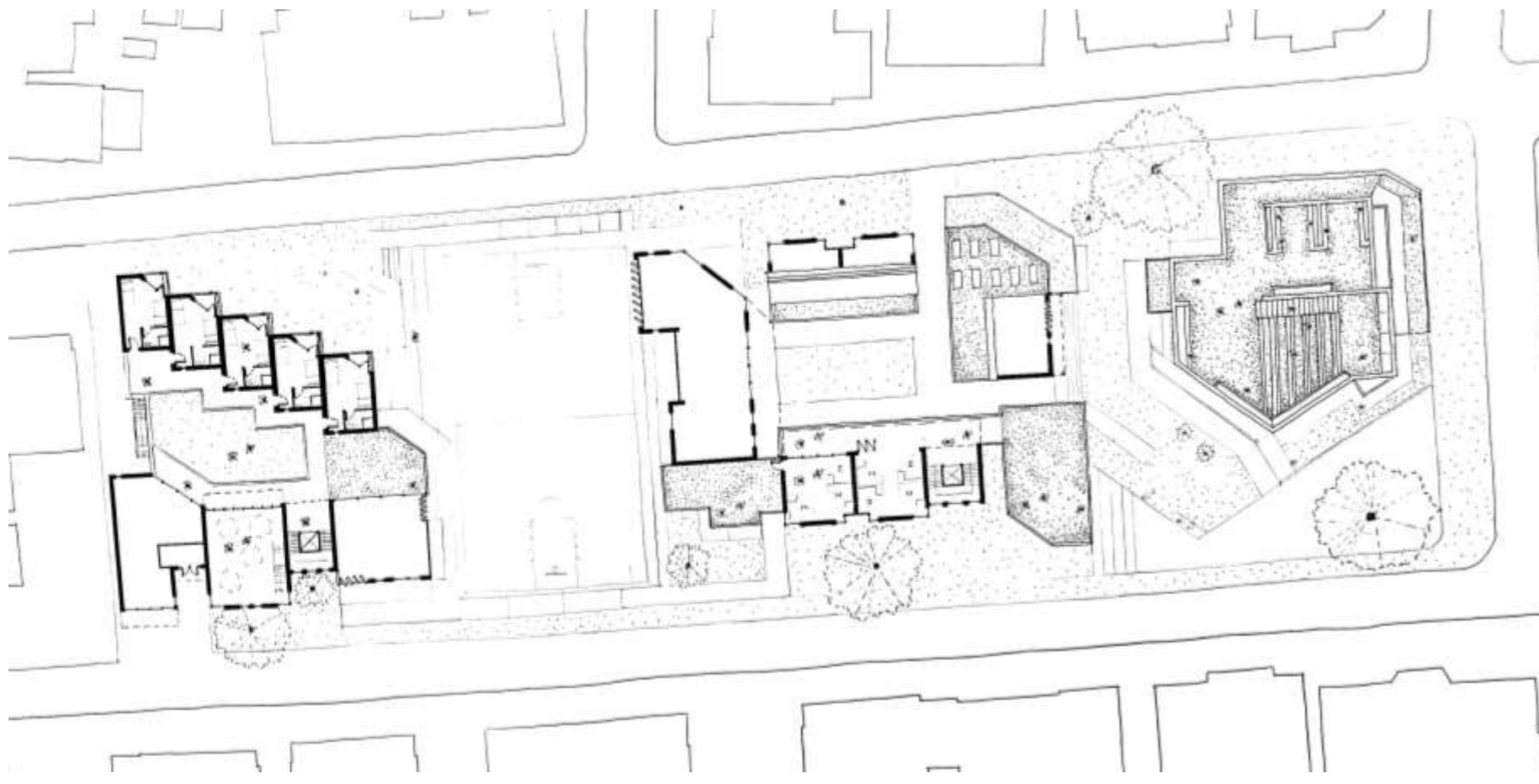

FIRST STOREY

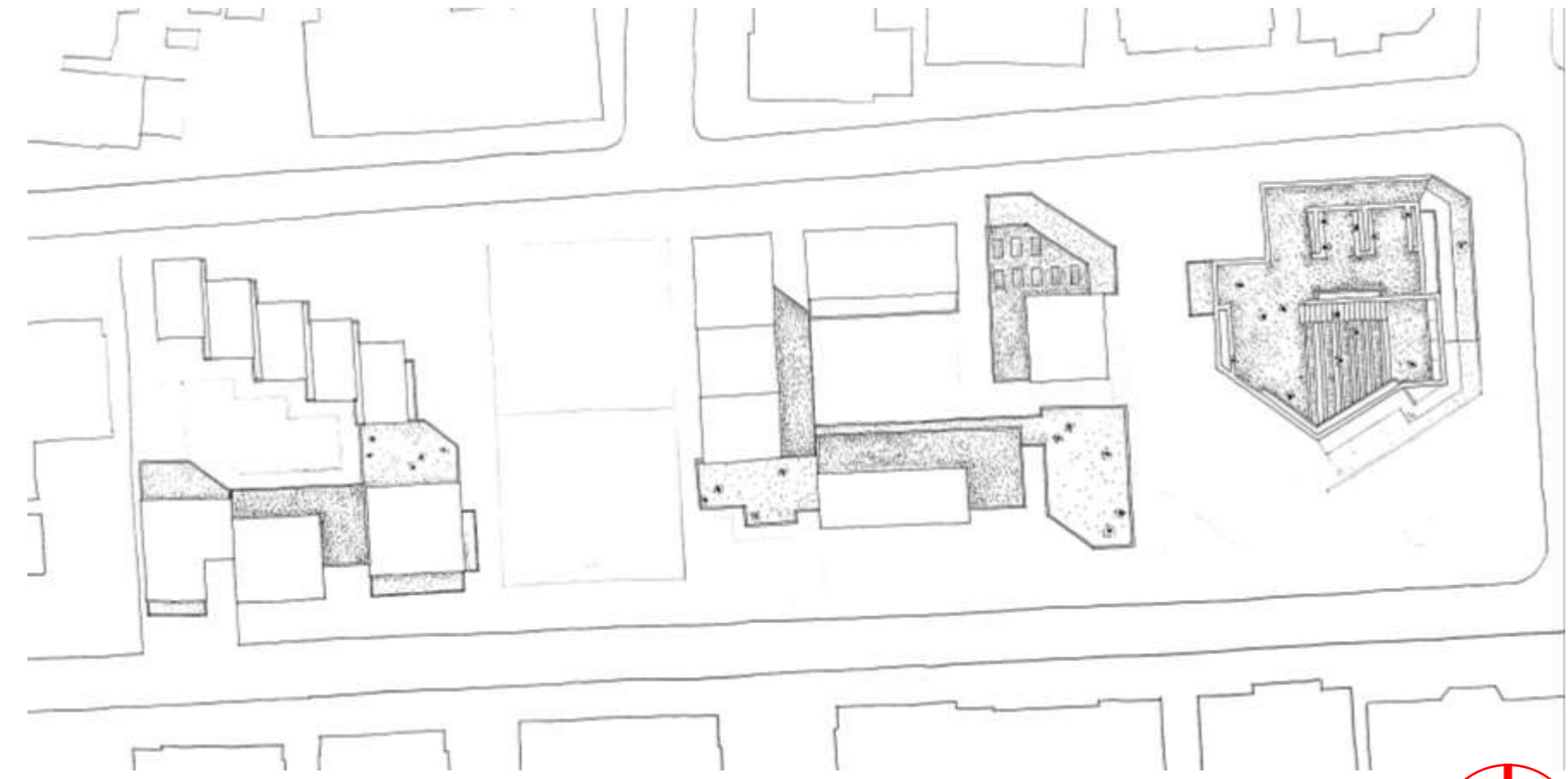

ROOF PLAN

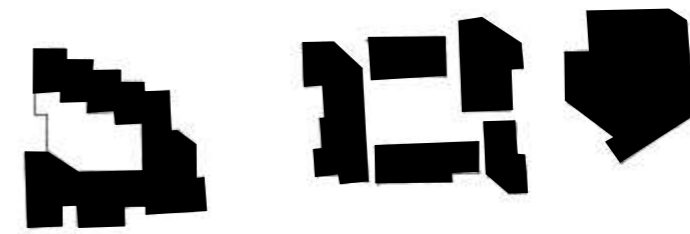

MASSING

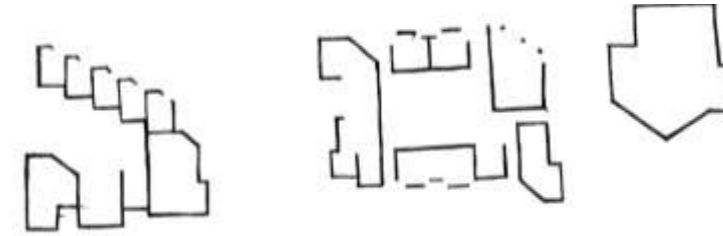

STRUCTURE

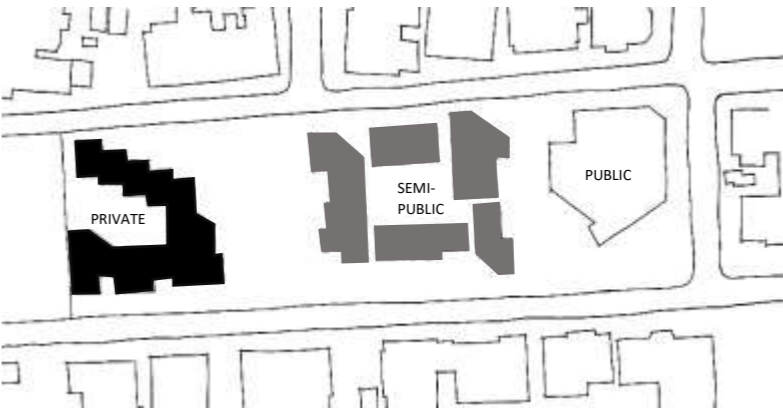

HEIRACHY ON SITE

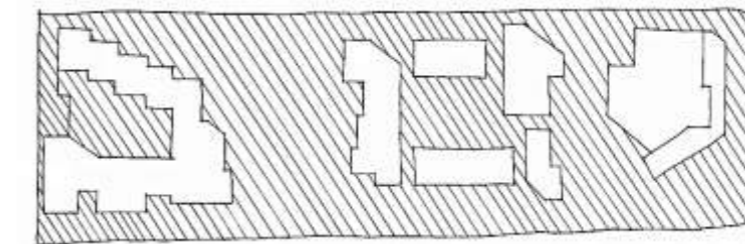

OPEN SPACE

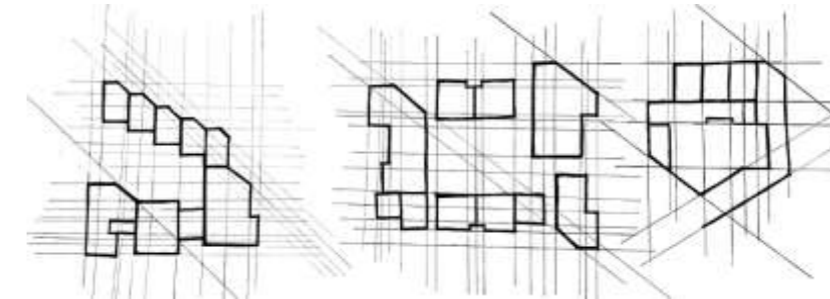

GEOMETRY

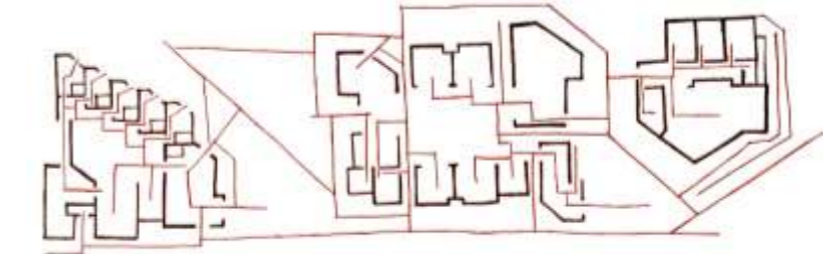

MOVEMENT THROUGH SITE

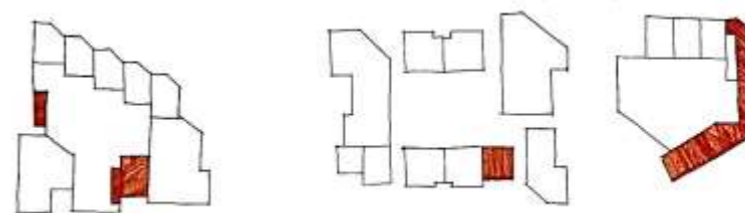

CIRCULATION TO ABOVE LEVEL

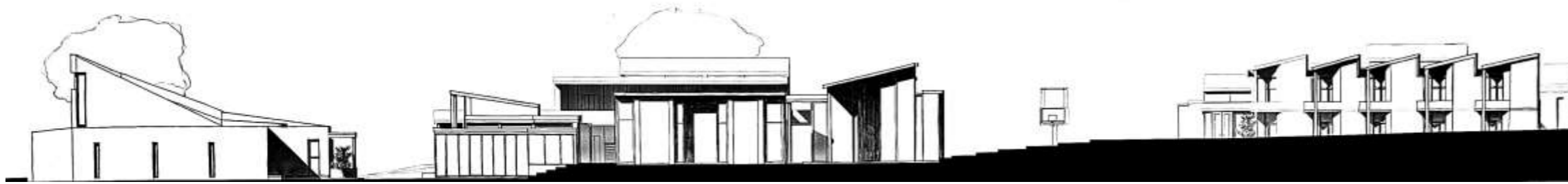

NORTH ELEVATION

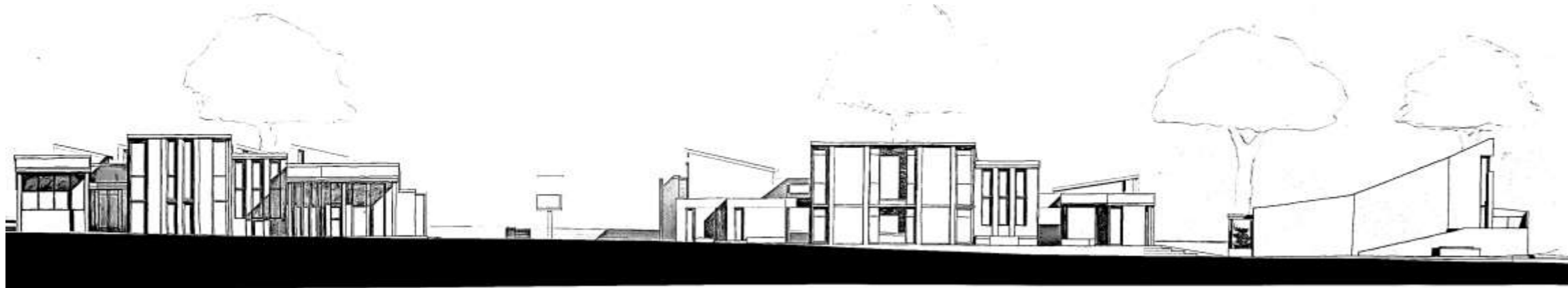

SOUTH ELEVATION



SECTION AA

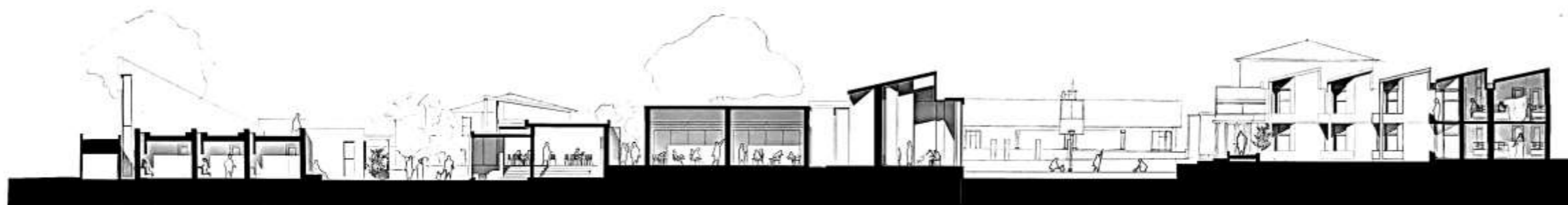

SECTION BB



SECTION CC



SECTION DD

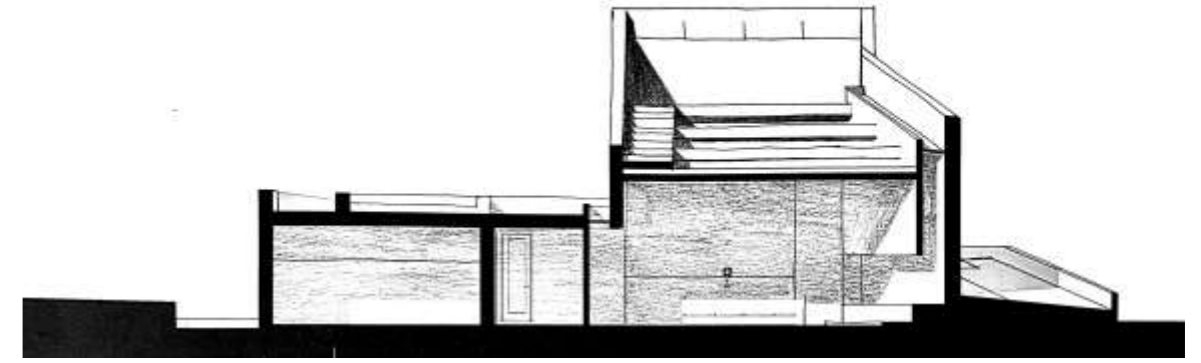

SECTION EE

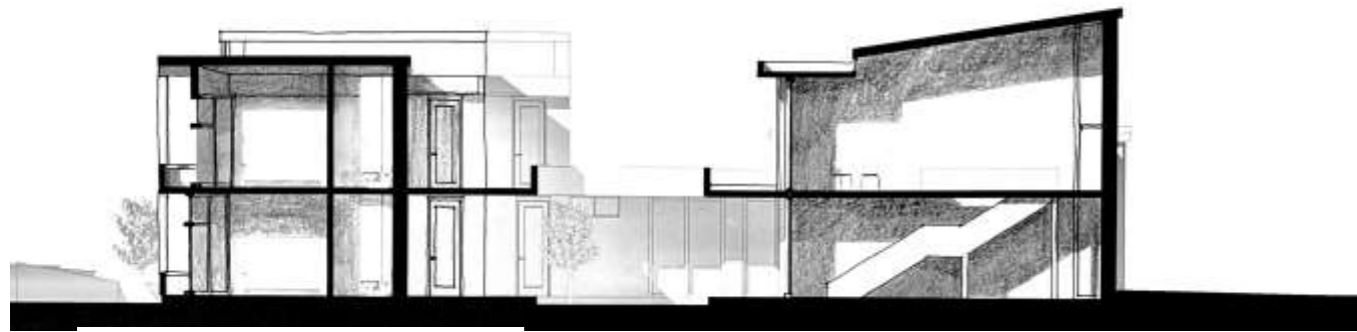

SECTION FF

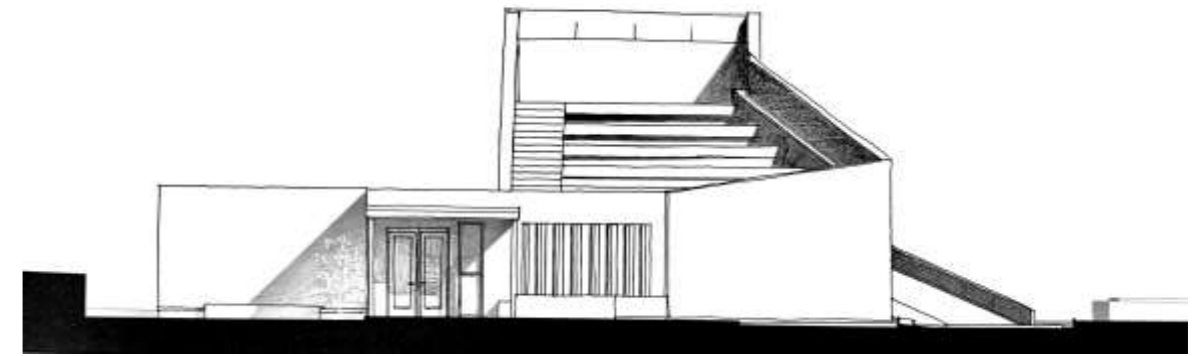

SECTION GG

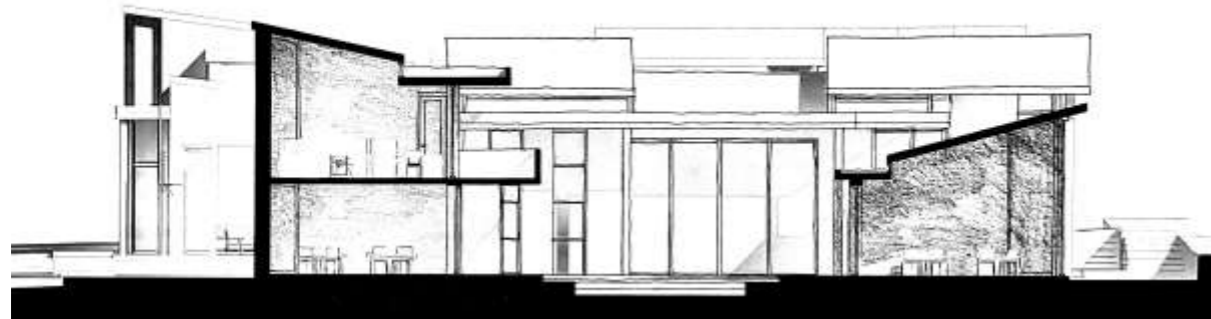

SECTION HH

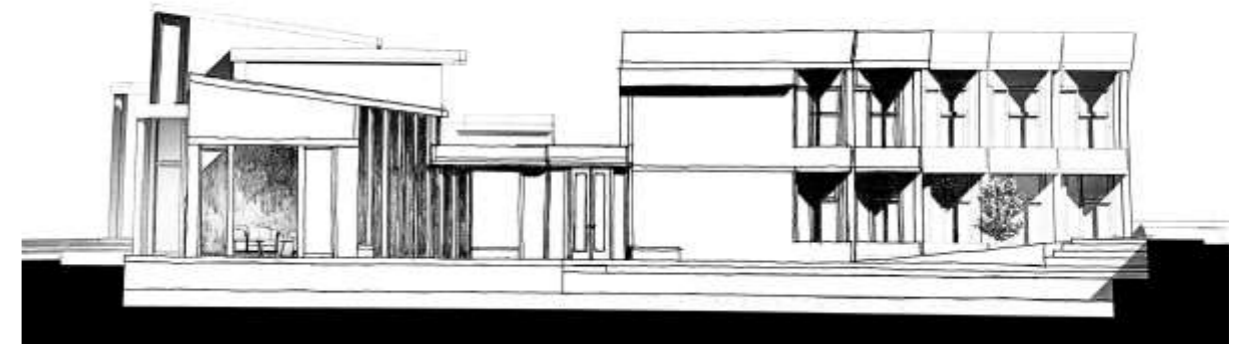

SECTION II



SECTION JJ



SECTION KK

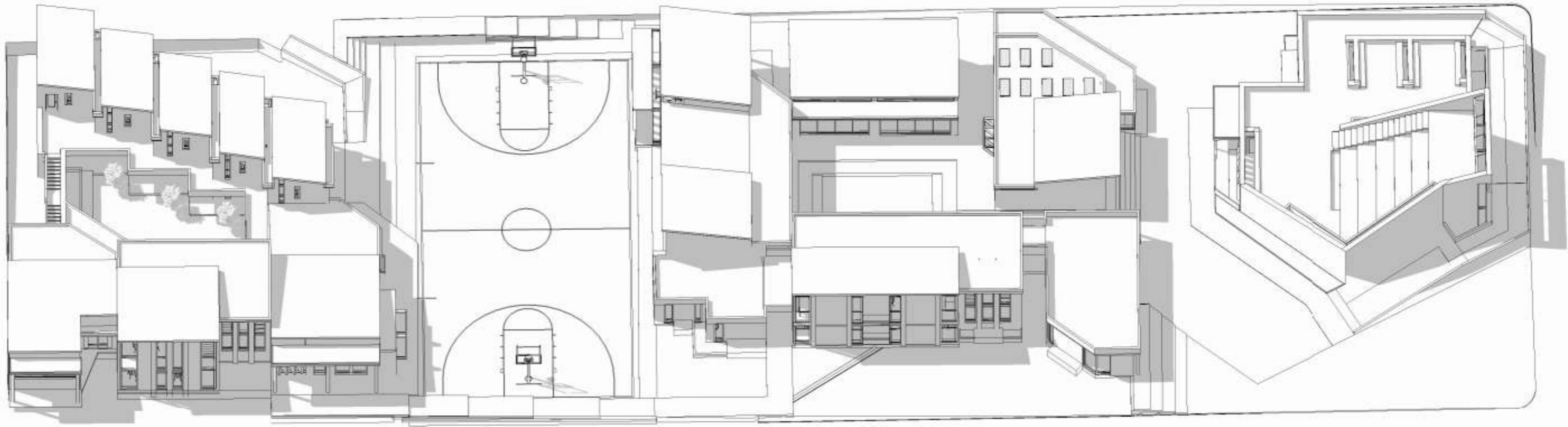

SOUTH VIEW

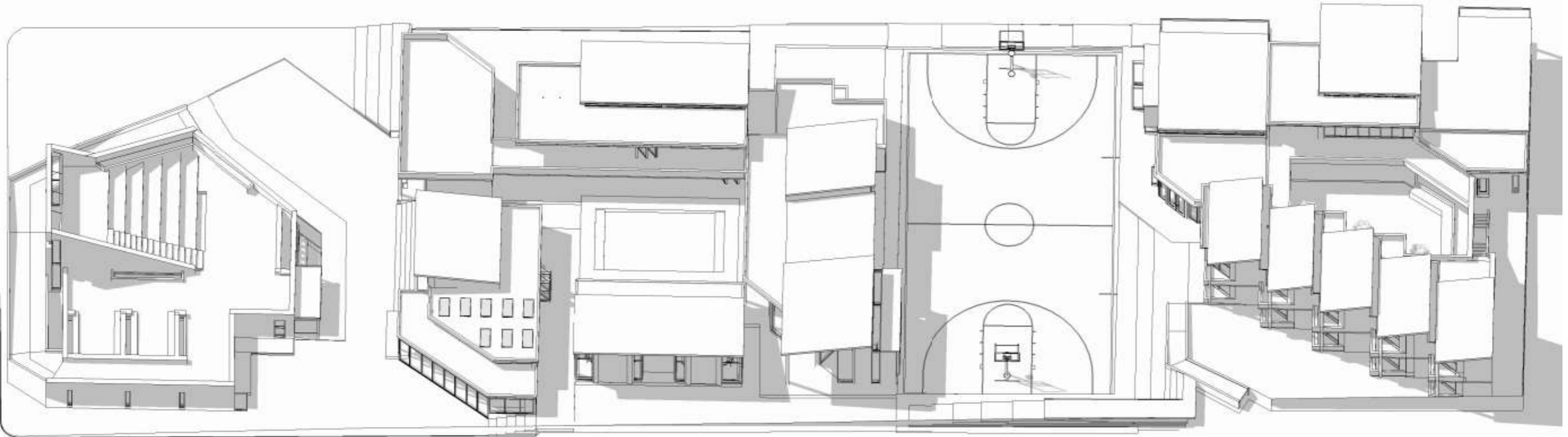

NORTH VIEW

TECHNICAL DEVELOPMENT OF CHURCH

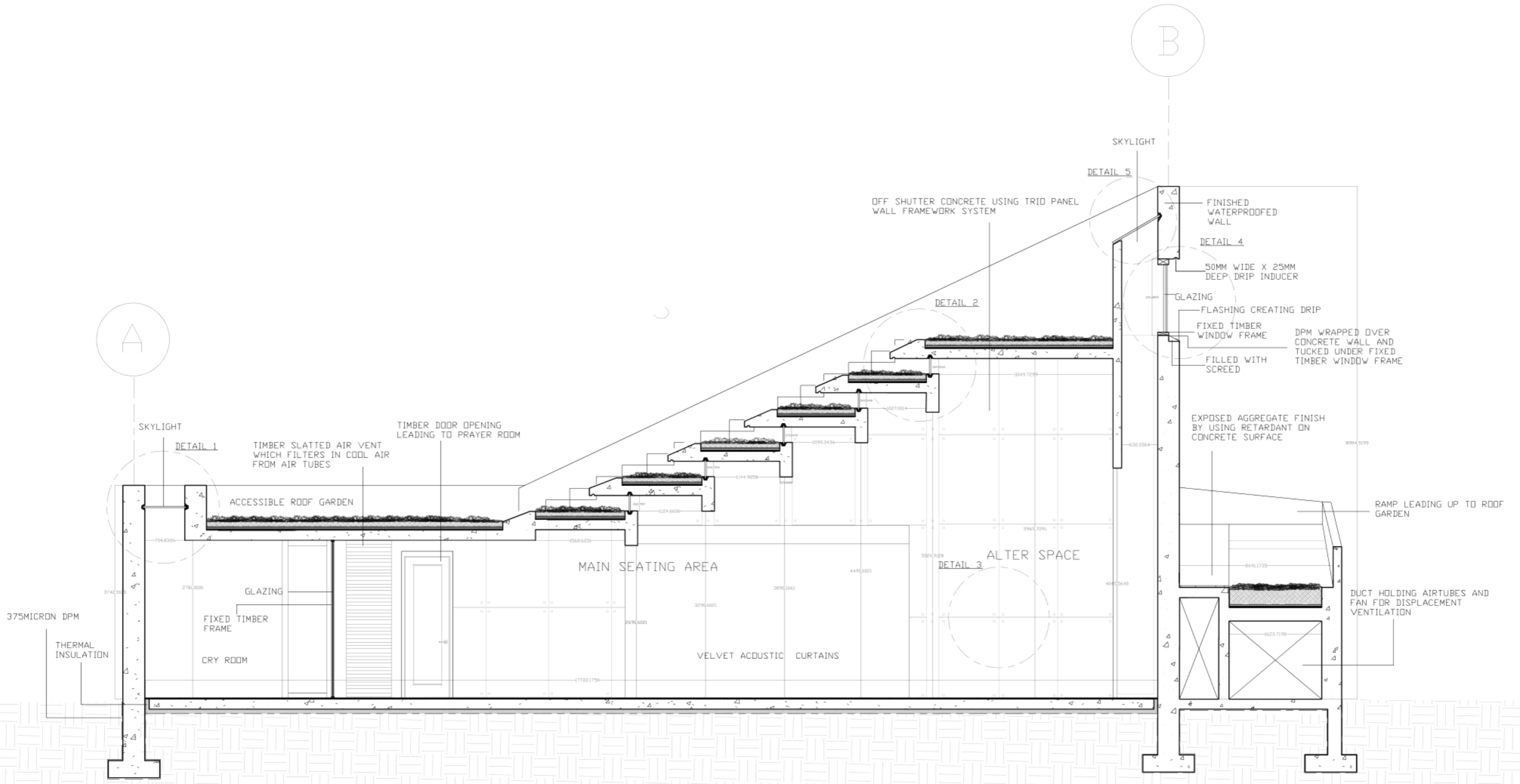

LONGITUDINAL SECTION

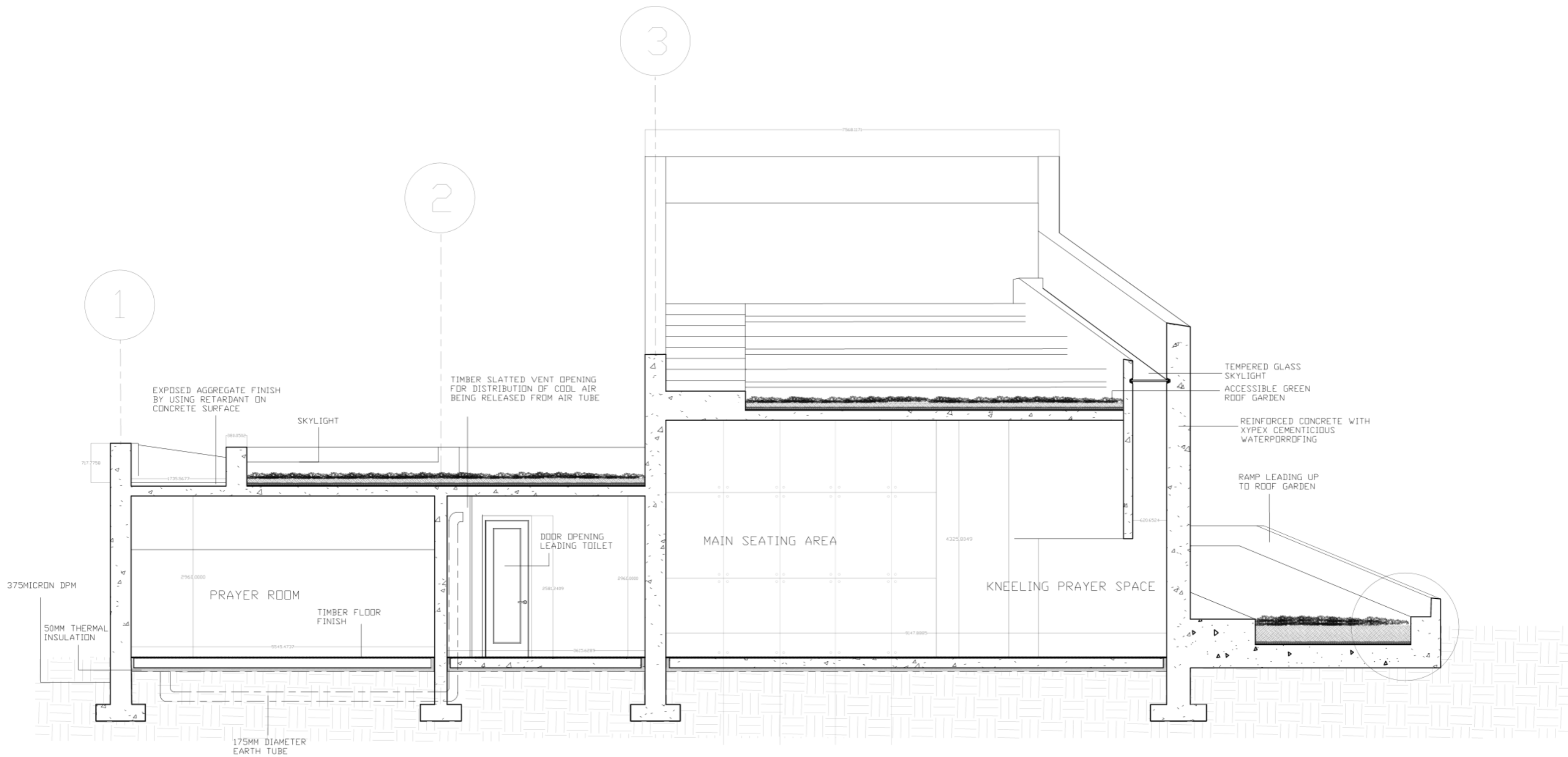

CROSS-SECTION

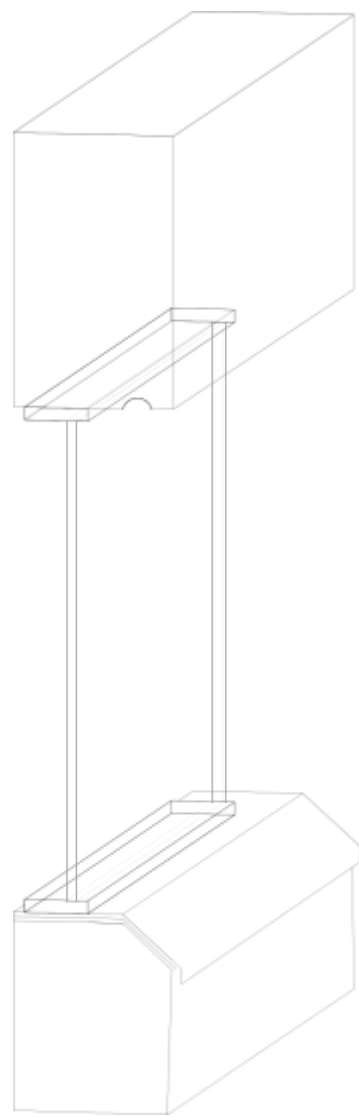

TIMBER WINDOW FRAME DETAIL

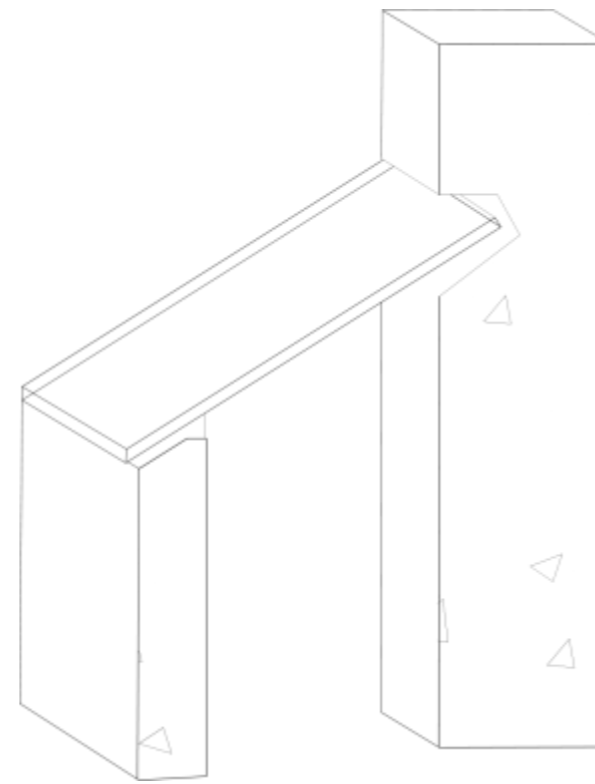
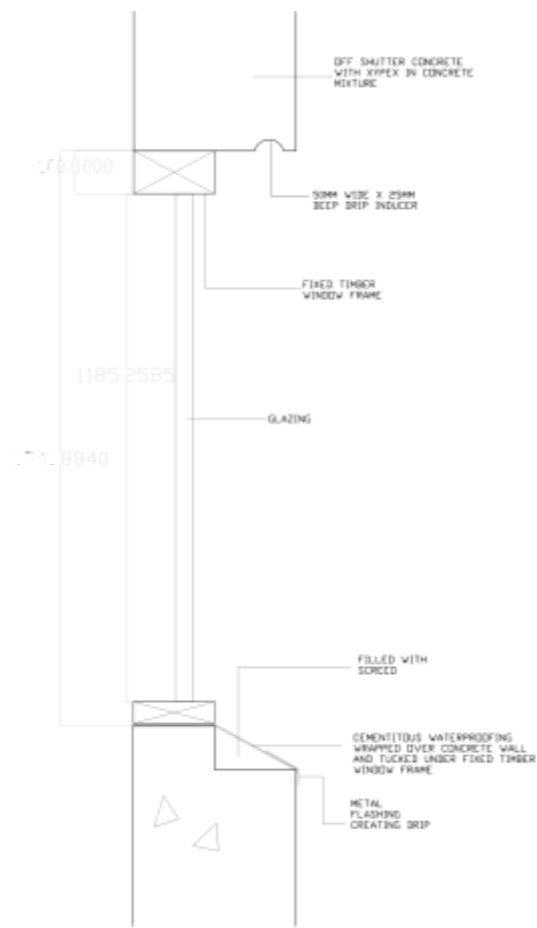

SKYLIGHT DETAIL 1

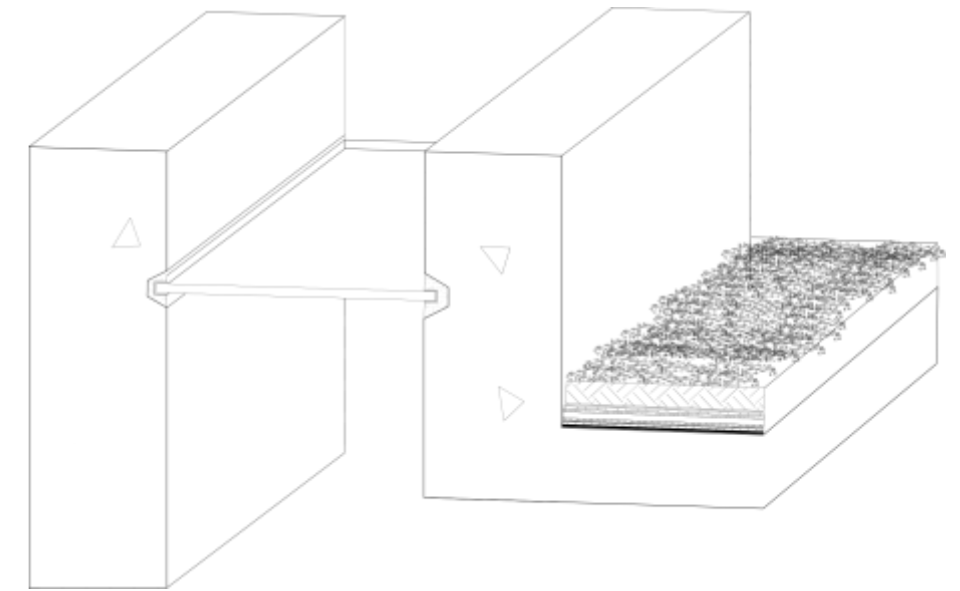
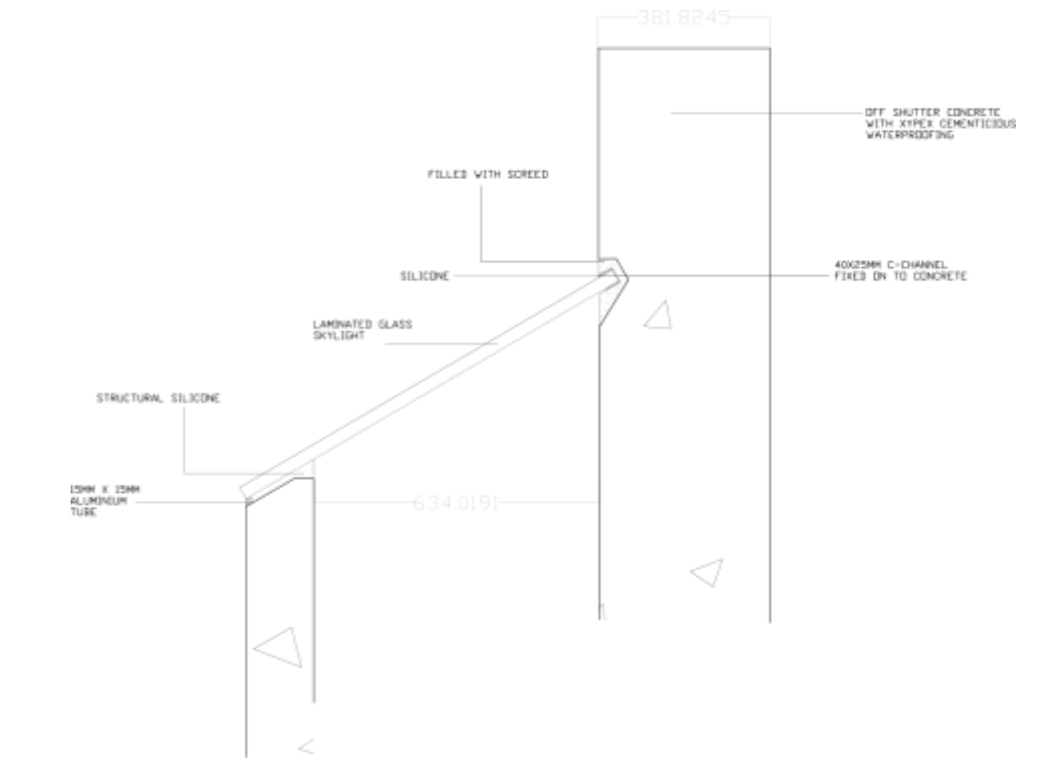

SKYLIGHT DETAIL 2

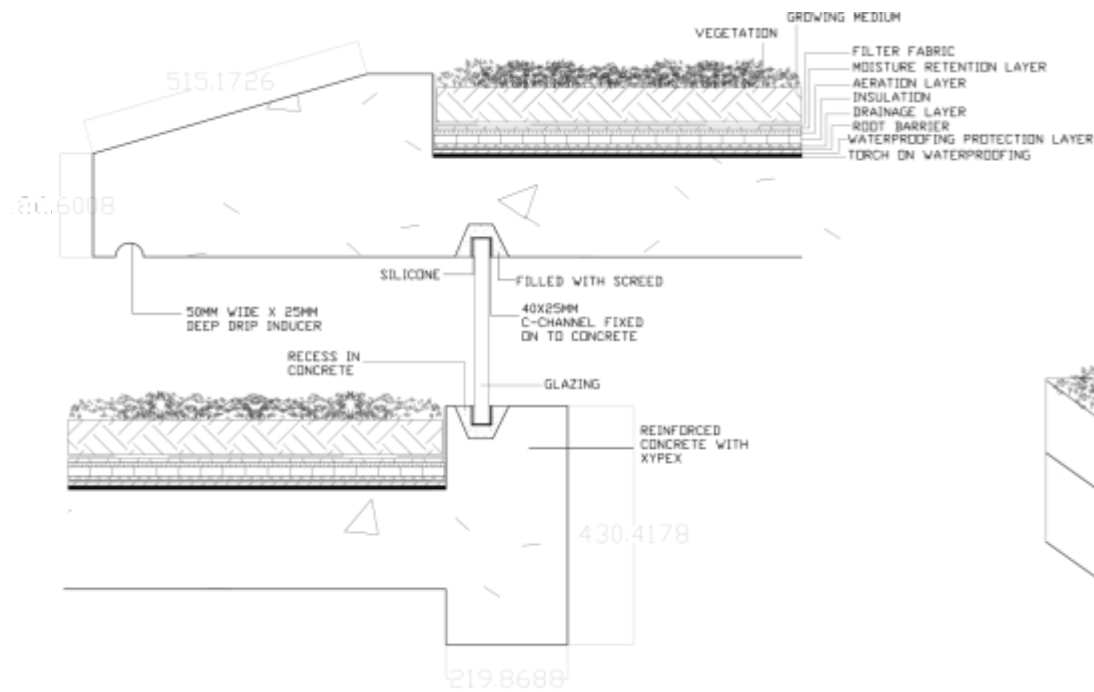

GREEN ROOF STEP DETAIL

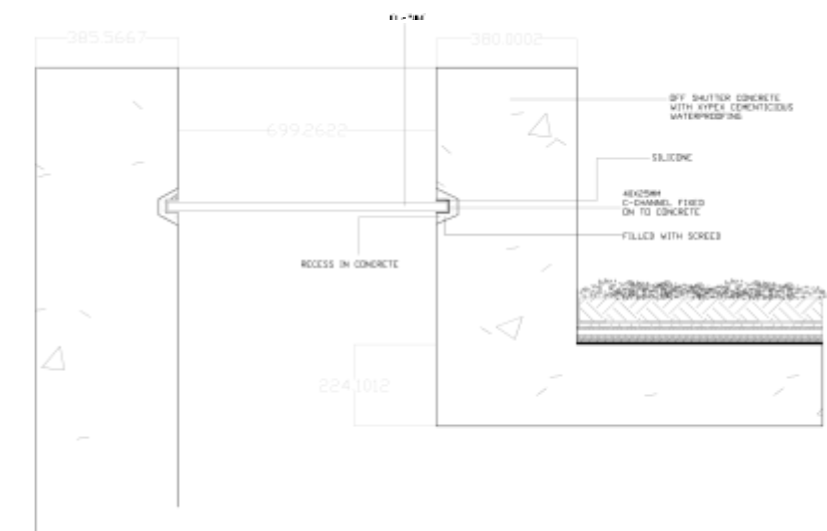
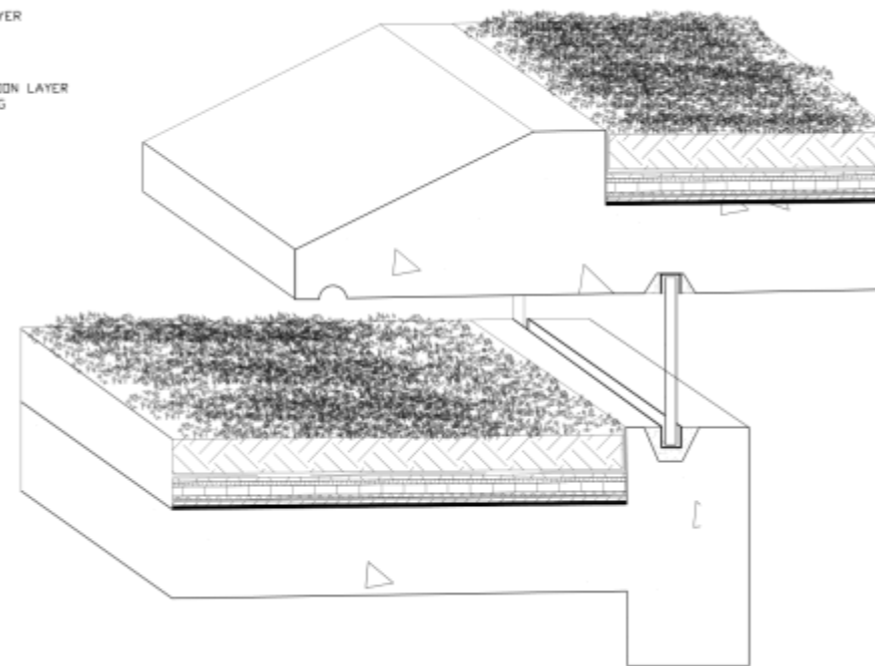

CHURCH RENDERS











LEARNING BLOCK RENDERS















ACCOMIDATION BLOCK RENDERS









